

Wilo-Yonos ECO BMS



de Einbau- und Betriebsanleitung
en Installation and operating instructions
fr Notice de montage et de mise en service
nl Inbouw- en bedieningsvoorschriften
it Istruzioni di montaggio, uso e manutenzione

sv Monterings- och skötselanvisning
no Monterings- og driftsveiledning
fi Asennus- ja käyttöohje
pl Instrukcja montażu i obsługi

Fig. 1:

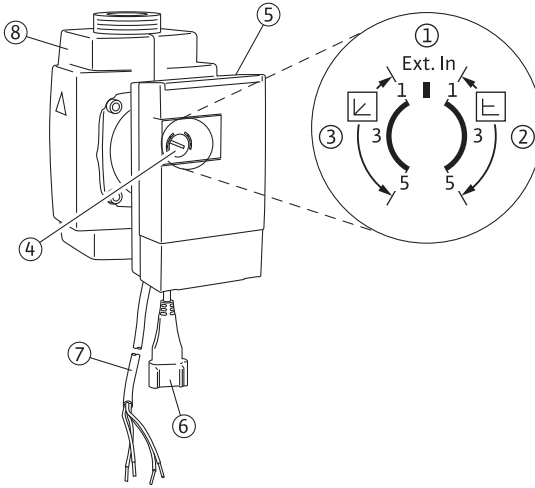

Fig. 2a:

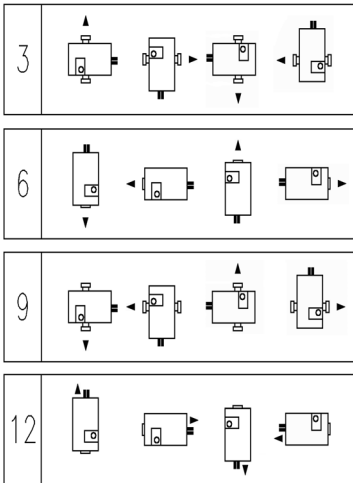

Fig. 2b:

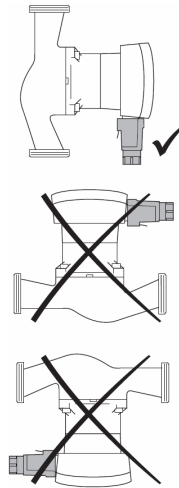

Fig. 3a:

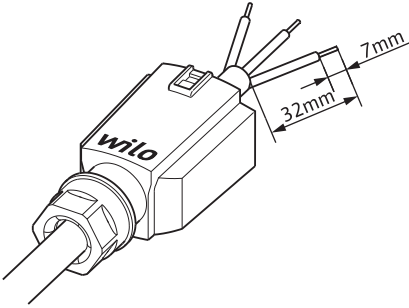

Fig. 3b:

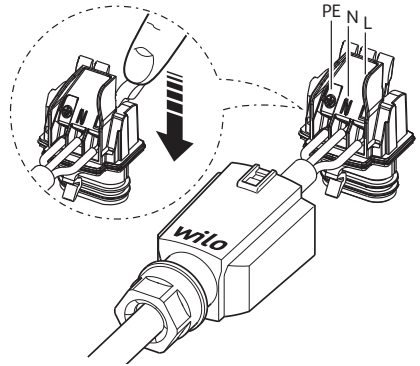

Fig. 3c:

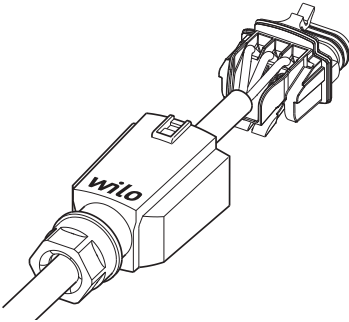

Fig. 3d:

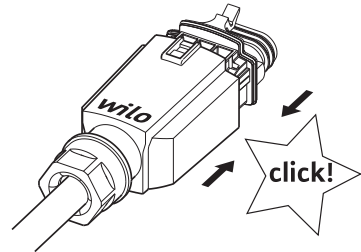

Fig. 3e:

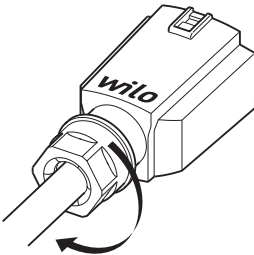

Fig. 4:

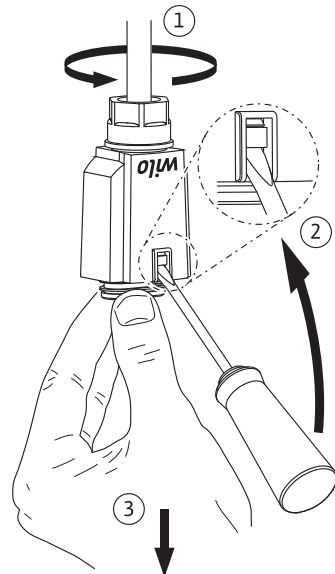

Fig. 5:

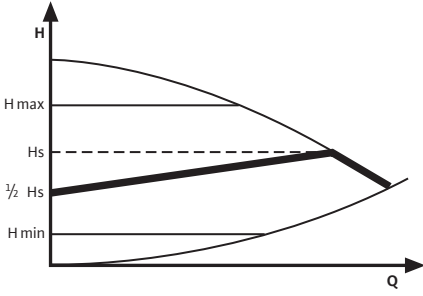

Fig. 6:

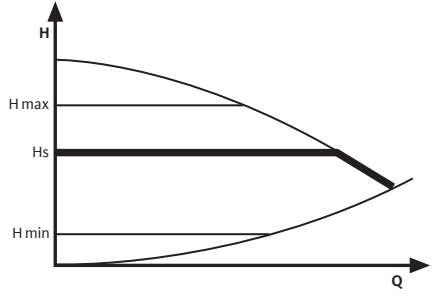
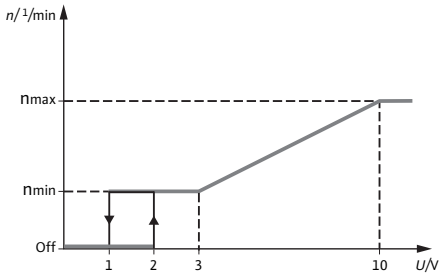

Fig. 7:



1 General

About this document

The language of the original operating instructions is German. All other languages of these instructions are translations of the original operating instructions.

These installation and operating instructions are an integral part of the product. They must be kept readily available at the place where the product is installed. Strict adherence to these instructions is a precondition for the proper use and correct operation of the product.

These installation and operating instructions correspond to the relevant version of the product and the underlying safety regulations and standards valid at the time of going to print. EC declaration of conformity:

A copy of the EC declaration of conformity is a component of these operating instructions. If a technical modification is made on the designs named there without our agreement or the declarations made in the installation and operating instructions on product/personnel safety are not observed, this declaration loses its validity.

2 Safety

These operating instructions contain basic information which must be adhered to during installation, operation and maintenance. For this reason, these operating instructions must, without fail, be read by the service technician and the responsible specialist/operator before installation and commissioning.

It is not only the general safety instructions listed under the main point "safety" that must be adhered to but also the special safety instructions with danger symbols included under the following main points.

2.1 Symbols and signal words in the operating instructions

Symbols:



General danger symbol



Danger due to electrical voltage



NOTE:

Signal words:

DANGER!

Acutely dangerous situation.

Non-observance results in death or the most serious of injuries.

WARNING!

The user can suffer (serious) injuries. "Warning" implies that (serious) injury to persons is probable if this information is disregarded.

CAUTION!

There is a risk of damaging the product/unit. "Caution" implies that damage to the product is likely if this information is disregarded.

NOTE:

Useful information on handling the product. It draws attention to possible problems.

Information that appears directly on the product, such as:

- Flow direction symbol,
 - Identification for connections,
 - Rating plate,
 - Warning sticker,
- must be strictly complied with and kept in legible condition.

2.2 Personnel qualifications

The installation, operating and maintenance personnel must have the appropriate qualifications for this work. Area of responsibility, terms of reference and monitoring of the personnel are to be ensured by the operator. If the personnel are not in possession of the necessary knowledge, they are to be trained and instructed. This can be accomplished if necessary by the manufacturer of the product at the request of the operator.

2.3 Danger in the event of non-observance of the safety instructions

Non-observance of the safety instructions can result in risk of injury to persons and damage to the environment and the product/unit. Non-observance of the safety instructions results in the loss of any claims to damages.

In detail, non-observance can, for example, result in the following risks:

- Danger to persons due to electrical, mechanical and bacteriological factors
- Damage to the environment due to leakage of hazardous materials
- Property damage
- Failure of important product/unit functions
- Failure of required maintenance and repair procedures

2.4 Safety consciousness on the job

The safety instructions included in these installation and operating instructions, the existing national regulations for accident prevention together with any internal working, operating and safety regulations of the operator are to be complied with.

2.5 Safety instructions for the operator

This appliance is not intended for use by persons (including children) with reduced physical, sensory or mental capabilities, or lack of experience and knowledge, unless they have been given supervision or instruction concerning use of the appliance by a person responsible for their safety.

Children should be supervised to ensure that they do not play with the appliance.

- If hot or cold components on the product/the unit lead to hazards, local measures must be taken to guard them against touching.
- Guards protecting against touching moving components (such as the coupling) must not be removed whilst the product is in operation.
- Leakages (e.g. from the shaft seals) of hazardous fluids (which are explosive, toxic or hot) must be led away so that no danger to persons or to the environment arises. National statutory provisions are to be complied with.
- Highly flammable materials are always to be kept at a safe distance from the product.
- Danger from electrical current must be eliminated. Local directives or general directives (e.g. IEC, VDE etc.) and instructions from local energy supply companies must be adhered to.

2.6 Safety instructions for installation and maintenance work

The operator must ensure that all installation and maintenance work is carried out by authorised and qualified personnel, who are sufficiently informed from their own detailed study of the operating instructions.

Work on the product/unit must only be carried out when at a standstill. It is mandatory that the procedure described in the installation and operating instructions for shutting down the product/unit be complied with.

Immediately on conclusion of the work, all safety and protective devices must be put back in position and/or recommissioned.

2.7 Unauthorised modification and manufacture of spare parts

Unauthorised modification and manufacture of spare parts will impair the safety of the product/personnel and is not permitted. This also applies to all installed plug and cable connections on the product. Non-observance results in a loss of any claims to damages and it will void the manufacturer's declarations regarding safety.

2.8 Improper use

The operating safety of the supplied product is only guaranteed for conventional use in accordance with Section 4 of the operating instructions. The limit values must on no account fall under or exceed those specified in the catalogue/data sheet.

3 Transport and interim storage

On arrival, immediately check the product and its packaging for damage in transit. If damage is detected, the necessary steps involving the forwarding agent must be taken within the specified period.



CAUTION! Risk of injuries to personnel and property damage!

Incorrect transport and interim storage can cause damage to the product and injury to personnel.

- **The pump and its packaging must be protected against moisture, frost and mechanical damage during transport and interim storage.**
- **Packaging that has become weakened loses its strength and call allow the product to fall out, causing injury to personnel.**
- **When the pump needs to be transported, it may be carried only by the motor/pump housing. Never by the control module or cable.**

4 Intended use

The high-efficiency pumps of the Wilo-Yonos ECO BMS series are for the circulation of liquids (no oils or liquids containing oil) in

- hot water heating systems
- cooling and cold water circuits
- closed-circuit industrial
- solar installations
- geothermal systems



WARNING! Health hazard!

Because of the materials used in their construction, pumps of the Wilo-Yonos ECO BMS series must not be used in applications involving drinking water or foodstuffs.

5 Product information

5.1 Type key

Example: Yonos ECO 25/1-5 BMS	
Yonos ECO	= high-efficiency pump
25	25 = nominal diameter 25
	Screwed connection: 25 (Rp 1), 30 (Rp 1¼)
1-5	1 = lowest selectable delivery head in [m] 5 = maximum delivery head in [m] at Q = 0 m ³ /h
BMS	Application for building automation

5.2 Technical data	
Max. volume flow	depends on the pump type, see catalogue
Max. delivery head	depends on the pump type, see catalogue
Speed	depends on the pump type, see catalogue
Mains voltage	1~230 V \pm 10% in acc. with DIN IEC 60038
Frequency	50/60 Hz
Rated current	See rating plate
Energy Efficiency Index (EEI) ¹⁾	See rating plate
Insulation class	See rating plate
Protection class	See rating plate
Power consumption P ₁	See rating plate
Nominal diameters	see type key
Pump weight	depends on the pump type, see catalogue
Permitted ambient temperature	-10 °C to +65 °C
Fluid temperatures at max. ambient temperature +40 °C	-10 °C to +95 °C
Fluid temperatures at max. ambient temperature +25 °C	-10 °C to +110 °C
Temperature class	TF110
Max. rel. humidity	≤ 95%
Maximum permissible operating pressure	PN 10
Approved fluids	<p>Heating water (as per VDI 2035/VdTÜV Tch 1466) Water/glycol mixtures, max. mixing ratio 1:1 (for mixtures with glycol the conveying data of the pump should be corrected to those for the higher viscosity, depending on the percentage mixing ratio) Only use brand-name goods with corrosion protection inhibitors; comply with the manufacturer's specifications and safety data sheets.</p> <p>The pump manufacturer's approval must be obtained for the use of other fluids.</p> <p>Ethylene/propylene glycol with corrosion inhibitors. No oxygen binding agents, no chemical sealants (ensure enclosed system from corrosion perspective according to VDI 2035; rework leaky points). Commercially available anti-corrosion agents²⁾ without corrosive anodic inhibitors (e.g. underdosing due to consumption). Commercially available combination products²⁾ without inorganic or polymer film formers. Commercially available cooling brines²⁾</p>
Emission sound-pressure level	< 32 dB(A)
Residual current DI	≤ 3.5 mA (also see chapter 7.2)
Electromagnetic compatibility	<p>Emitted interference in acc. with: EN 61800-3:2004+A1:2012 / Residential (C1) Interference resistance in acc. with: EN 61800-3:2004+A1:2012 / Industrial (C2)</p>

¹⁾ Reference value for the most efficient circulation pumps: EEI ≤ 0.20

²⁾ See the following warning



CAUTION! Risk of injury and damage to property!

Non-approved fluids can damage the pump and also cause injury.

Comply strictly with the relevant safety data sheets and manufacturer's data!

- 2) **Observe the specifications of the manufacturer regarding the mixing ratios.**
- 2) **Additives are to be mixed to the fluid on the pressure side of the pump, even if this is contrary to the recommendations of the additive manufacturer!**



CAUTION! Risk of property damage!

When changing, refilling or replenishing the fluid with additives, there is a risk of material damage caused by enrichment of chemical substances. The pump is to be flushed separately for a sufficient amount of time to ensure the old fluid has been completely removed from the interior of the pump.

For alternating pressure flushing, the pump must be detached. Chemical flushing is not suitable for the pump; in this case, the pump must be removed from the system for the duration of cleaning.

Minimum inlet pressure (above atmospheric pressure) at the pump suction port in order to avoid cavitation noises (at fluid temperature T_{Med}):

Nominal diameter	T_{Med}	T_{Med}	T_{Med}
	-10°C...+50°C	+95°C	+110°C
Rp 1	0.05 bar	0.45 bar	1.1 bar
Rp 1¼	0.05 bar	0.45 bar	1.1 bar

The values apply up to 300 m above sea level; addition for higher locations:
0.01 bar/100 m increase in height.

5.3 Scope of delivery

Pump assembly

- 2 gaskets
- Control cable (1.5 m) for SSM and 0–10V connection connected to pump at the factory.
- Wilo-Connector included
- Two-piece thermal insulation shell
 - Material: EPP, polypropylene foam
 - Thermal conductivity: 0.04 W/m as per DIN 52612
 - Flammability: B2 class as per DIN 4102, FMVSS 302
- Installation and operating instructions

5.4 Accessories

Accessories must be ordered separately:

See catalogue for a detailed description.

6 Description and function

6.1 Description of the pump

The pump consists of a hydraulic system, a glandless pump motor with a permanent magnet rotor, and an electronic control module with an integrated frequency converter. The control module contains a red operating knob (Fig. 1, item 4) that can be used to set the pump's differential pressure to an adjustable value between 1 and 5 m. The pump housing is clad with an insulating shell for thermal insulation.

6.2 Function of the pump

There is a **control module** (Fig. 1, item 5) in axial design on the motor housing, which controls the differential pressure of the pump to a setpoint within the control range. Depending on the control mode, the differential pressure follows different criteria. In all control modes, however, the pump adapts itself continuously to the changing power requirements of the unit, which is the case especially when thermostatic valves, zone valves or mixers are used.

The basic advantages of the electronic control are:

- Energy savings and hence reduction of the operating costs,
- Reduction of flow noises,
- Reduction of the number of differential pressure valves required.

6.2.1 Settings

On the front of the control module is the “red button” (Fig. 1, item 4) as a central operating element, which features three setting ranges.

The following settings can be made:



Variable differential pressure setting range (Dp-v):

Fig. 1, item 3: The control mode Dp-v is active



Constant differential pressure setting range (Dp-c):

Fig. 1, item 2: The control mode Dp-c is active

ext. in Setting range Ext. In:

Fig. 1, item 1: External speed adjustment by 0–10V analogue input.

6.2.2 Differential pressure control modes

Variable differential pressure (Dp-v):

The electronics change the differential pressure setpoint to be maintained by the pump in linear form between $\frac{1}{2}H_s$ and H_s . The differential pressure setpoint H_s falls or increases with the flow rate (Fig. 5), factory setting.

Constant differential pressure (Dp-c):

The electronics maintain the differential pressure created by the pump above the permitted flow range constantly at the selected differential pressure setpoint H_s up to the maximum pump curve (Fig. 6).

6.2.3 Control signal 0–10V

The function linked to the 0–10V analogue control signal behaves as follows (Fig. 7):

- $U < 1\text{ V}$: Pump stops
- $2\text{ V} < U < 3\text{ V}$: Pump runs at minimum speed (starting)
- $1\text{ V} < U < 3\text{ V}$: Pump runs at minimum speed (operation)
- $3\text{ V} < U < 10\text{ V}$: Speed varies between n_{\min} and n_{\max} (linear)

6.2.4 General functions of the pump

- The pump is equipped with an electronic overload protection function which switches off the pump in the event of an overload.

- Once power returns after a power interruption, the pump goes back into operation with different start-up times, depending on the setting chosen. See chapter 10.2 for the restart times.
- **SSM:** Faults always result in the activation of the collective fault signal (“SSM” via a relay). The contact of the collective fault signal (potential-free normally closed contact) can be connected to a building automation system. The internal contact is closed if the pump is without power, if there is no fault or if there is a malfunction of the control module. The performance of the SSM is described in chapters 7.2.2 and 10.1.

7 Installation and electrical connection



DANGER! Risk of fatal injury!

Incorrect installation and improper electrical connections can be life-threatening. Danger from electrical current must be eliminated.

- **The installation and electrical connection may only be carried out by qualified personnel in accordance with the applicable regulations!**
- **Adhere to regulations for accident prevention!**
- **Comply with the regulations of the local energy supply company!**



CAUTION! Risk of property damage!

Excessive force on the control module of the pump is to be avoided.

- **The mains and control cable of the Yonos ECO BMS series can only be connected at the factory. Subsequent installation is not possible.**
- **Never pull on the pump cable!**
- **Do not kink the cable!**
- **Do not place any objects on the cable!**

7.1 Installation



WARNING! Risk of injury!

Incorrect installation can result in personal injury.

- **There is a crushing hazard!**
- **There is a risk of injury due to sharp edges/burrs. Wear appropriate protective clothing (e.g. safety gloves)!**
- **There is a risk of injury hazard due to the pump/motor falling!**
Use suitable lifting gear to secure the pump/motor against falling!



CAUTION! Risk of property damage!

Incorrect installation can result in property damage.

- **Only use qualified personnel for installation work!**
- **Observe national and regional regulations!**
- **When the pump needs to be transported, it may be carried only by the motor/pump housing.**
Never by the control module or preinstalled cable!
- Installation within a building:
Install the pump in a dry, well-ventilated room. Ambient temperatures below -10°C are not permitted.
- Installation outside a building (outdoor installation):
 - Install the pump in a chamber (e.g. light well, ring chamber) with a cover or in a cabinet/housing as weather protection.
 - Avoid exposure of the pump to direct sunlight.
 - Protect the pump against rain.

- The minimum ambient temperature should not fall below the freezing point of the fluid nor should it be lower than $-10\text{ }^{\circ}\text{C}$.
- The fluid and ambient temperature should not exceed or fall below the permissible values ??(see chapter 5.2).



CAUTION! Risk of property damage!

Provide adequate ventilation/heating in situations where the permitted ambient temperature is exceeded or fallen short of.

- Carry out all welding and soldering work prior to the installation of the pump.



CAUTION! Risk of property damage!

Contamination from the pipe system can destroy the pump during operation. Before installing the pump, flush the pipe system.

- Provide shut-off devices upstream and downstream of the pump.
- When installing in the feed of open systems, the safety supply must branch off upstream of the pump (DIN EN 12828).
- Remove the two half shells of the thermal insulation (Fig. 1, item 8) before installing the pump.
- Install the pump at an easily accessible point so that it can be easily checked or replaced at a later time.
- Precautions during installation:
 - Perform assembly so that the pump shaft is horizontal and not under strain (see the installation positions shown in Fig. 2a/2b).
 - Make sure that it is possible to install the pump with the correct flow direction (cf. Fig. 2a/2b). The flow direction symbol on the pump housing indicates the direction of flow.
 - Make sure that it is possible to install the pump in the permitted installation position (cf. Fig. 2a/2b). If required, turn the motor including control module, see Chapter 9.1.
- Install appropriate threaded pipe unions before installing the pump.
- Use the supplied flat gaskets between the suction/pressure ports and threaded pipe unions when installing the pump.
- Screw union nuts onto the threads of the suction/pressure ports and tighten them using an open-end wrench or pipe wrench.



CAUTION! Risk of property damage!

Do not hold the pump by the motor/control module when tightening the screwed connections. Apply the wrench surfaces to the suction/pressure port instead.

- Check the threaded pipe unions for leaks.

7.1.1 Insulation of the pump in heating systems

Before commissioning, position the two half shells of the thermal insulation (Fig. 1, item 8) and press them together.



WARNING! Risk of burns!

Depending on the pump or system operating conditions (fluid temperature), the entire pump can become very hot.

When retrofitting the insulation during normal operation there is a risk of burns.

7.1.2 Insulation of the pump in cooling/air-conditioning systems

The thermal insulation shells (Fig. 1, item 8) included in the scope of delivery may only be used in heating applications at fluid temperatures of +20°C or higher, since these thermal insulation shells do not enclose the pump housing in a diffusion-proof manner. The pumps of the Wilo-Yonos ECO BMS series are suitable for use in air-conditioning, cooling, geothermal energy and other similar systems with fluid temperatures down to -10°C. Condensate can form on parts that come into contact with the fluid, such as pipes and pump housings.

- A diffusion-proof insulation must be provided on-site for application in systems such as these.
- Condensate cannot form on the inside of Yonos ECO BMS pumps due to the special design of the motor.
- To protect against corrosion, the pump housing is provided with a cathaporetic coating.

7.2 Electrical connection



DANGER! Risk of fatal injury!

Improper electrical connections can lead to fatal electric shocks.

- **Only allow the electrical connection to be made by an electrician approved by the local power supply company and in accordance with the local regulations in force.**
- **Before working on the pump, all poles of the power supply must be disconnected. Work on the pump may only be started after 5 minutes have elapsed due to the dangerous residual contact voltage.**
- **Check whether all connections (including potential-free contacts) are voltage-free.**
- **If the control module/cable is damaged, do not operate the pump.**
- **If setting and operating elements are improperly removed from the control module, there is a danger of electric shock if interior electrical components are touched.**
- **The pump should neither be connected to an IT network nor to an uninterruptible power supply**



CAUTION! Risk of property damage!

An incorrect electrical connection can cause damage to property.

- **If the wrong voltage is applied, the motor can be damaged!**
- **Control via triacs/semiconductor relay is not permitted!**
- **When conducting insulation tests with a high voltage generator, the pump must be completely disconnected from the mains in the system's switchbox.**
- The current type and voltage of the mains connection must correspond to the details on the rating plate.
- The mains cable (Fig. 1, item 6) and the control cable (Fig. 1, item 7) used for the Yonos ECO BMS pump is permanently connected to the control module.



DANGER! Danger of electric shock!

If the cable has been separated from the pump as a result of force, there is a risk of personal injury by electric shock.

The connection cable is not removable!







CAUTION! Risk of property damage!

Modifications to the connection cable can cause damage to property.

The cable can only be connected at the factory.

Subsequent installation is not possible.

- The electrical connection must be established via a fixed power cable (3 x 1.5 mm² minimum cross-section), equipped with a plug and socket connector or an all-pole switch with a minimum contact opening width of 3 mm.
- The following minimum requirements are to be met if shutdown takes place by means of an on-site network relay: Rated current ≥ 8 A, rated voltage 250 VAC, Contact materials: AgSnO₂ or Ag/Ni 90/10
- Fuse protection: 10/16 A, slow-blow or automatic fuse with C characteristic.
- A motor protection switch supplied by the customer is not required. Nevertheless, if such a protection switch is available in the installation, it must be bypassed or set to the highest possible current.
- Leakage current per pump $I_{\text{eff}} \leq 3.5$ mA (in acc. with EN 60335)
- It is recommended to safeguard the pump with a residual-current device.
Labelling: RCD type A  or RCD type B  
When dimensioning the residual-current device, consider the number of pumps connected and their rated motor currents.
- All connection cables must be installed so that they do not touch the pipe and/or the pump or motor housing.
- Earth the pump/installation in accordance with the regulations.
- L, N, : Mains supply voltage: 1~230 VAC, 50/60 Hz, DIN IEC 60038

7.2.1 Installation/dismantling of the Wilo-Connector

- Disconnect the connecting cable from the power supply.
- Observe the terminal allocations (PE, N, L).
- Connect and fit the Wilo-Connector (Figs. 3a to 3e).
- Connect the Wilo-Connector to the mains cable with the connection housing (Fig. 1, item 6) until it snaps into place.
Dismantle the Wilo-Connector in accordance with Fig. 4. A screwdriver is needed for this.

7.2.2 Assignment of the control cable

The Yonos ECO BMS pump is fitted at the factory with a control cable (1.5 m) for the SSM connection and 0–10V (Fig. 1, item. 7).

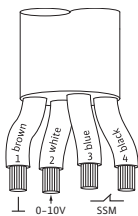

- Wire 1 (brown): GND (signal earth)
- Wire 2 (white): 0...10 V (signal)
- Wire 3 (blue): SSM
- Wire 4 (black): SSM



NOTE: To ensure interference resistance the total length of the 0–10 V control cable should not exceed 15m

- **0–10V:**
 - Electric strength 24V DC
 - Input resistance of the voltage input >100 kOhm

- **SSM:**

An integrated collective fault signal is applied as a potential-free normally closed contact.
Contact load:

- Permitted minimum: 12 V DC, 10 mA
- Permitted maximum: 250 V AC, 1 A



DANGER! Risk of fatal injury!

Improper connection of the collective fault signal (SSM) contact poses a risk of fatal injury due to electric shock.

When connecting the SSM to the mains potential, the phase to be connected and phase L1 on the mains connection cable of the pump must be identical.

- **Switching frequency:**

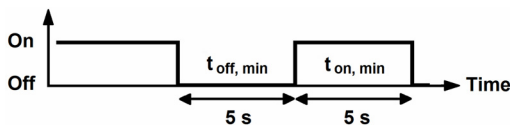

- Interval between the switching times: at least 5 s
- Switch on/switch off procedures via mains voltage $\leq 300\,000$ switching cycles during the service life (80 000 operating hours).
- Switch on/switch off procedures over 0–10V $\leq 500,000$ switching cycles during the service life (80,000 operating hours)

8 Commissioning

Do not fail to observe the danger information and warnings in Chapters 7, 8.4 and 9!
Prior to commissioning the pump, check that it was installed and connected correctly.

8.1 Filling and venting



NOTE: Incomplete venting will result in noises in the pump and unit.

Prime and vent the unit correctly. The pump rotor room is vented automatically after a short operating period. Dry running for short periods will not harm the pump.



WARNING! Risk of injury and damage to property!

It is not permitted to remove the motor head or the flange connection / threaded pipe union for the purpose of venting the system!

- **There is a risk of scalding!**
Escaping fluid can lead to injuries to persons and damage to the product.
- **Touching the pump can cause burns!**
Depending on the pump or system operating conditions (fluid temperature), the entire pump can become very hot.

8.2 Selecting the control mode

System type	System conditions	Recommended control mode
Heating/ventilation/air-conditioning systems with resistance in the transfer section (room radiator + thermostatic valve) \leq 25% of the total resistance	<ol style="list-style-type: none"> Two-pipe system with thermostatic/zone valves and virtually no user authority <ul style="list-style-type: none"> $H_N > 4$ m Very long distribution lines Strongly throttled line stop valves Sectional differential pressure control High pressure loss in system parts through which total volume flows (boiler/refrigerating machine, any heat exchanger, distribution line up to 1st branch) Primary circuits with high pressure loss 	Dp-v
Heating/ventilation/air-conditioning systems with resistance in the generator/distribution circuit \leq 25% of the resistance in the transfer section (room radiator + thermostatic valve)	<ol style="list-style-type: none"> Two-pipe system with thermostatic/zone valves and high user authority <ul style="list-style-type: none"> $H_N \leq 2$ m Converted gravity heating systems Conversion to large temperature spread (e.g. district heating) Low pressure loss in system parts, through which total volume flows (boiler/refrigerating machine, any heat exchanger, distribution line up to 1st branch) Primary circuits with minor pressure loss Underfloor heating systems with thermostatic or zone valves One-pipe systems with thermostatic valves or line stop valves 	Dp-c

8.3 Adjusting the pump output

During planning, the unit is designed for a specific duty point (hydraulic full-load point for maximum heating power requirement calculated). During commissioning, the pump output (delivery head) is set according to the duty point of the system. The factory setting does not correspond to the output required for the system. It is determined with the help of the pump curve diagram for the selected pump type (from catalogue/data sheet). See also Figs. 5 and 6.

Control modes Dp-c and Dp-v:

	Dp-c (Fig. 6)	Dp-v (Fig. 5)
Duty point on maximum pump curve	Starting at the duty point, draw towards the left. Read off setpoint H_S and set the pump to this value.	
Duty point within the control range	Starting at the duty point, draw towards the left. Read off setpoint H_S and set the pump to this value.	Move to max. pump curve along control curve, then horizontally to the left, read off setpoint H_S and set the pump to this value.
Setting range	H_{\min} , H_{\max} , see 5.1 Type key	

8.4 Operation

Faults of electronic devices due to electromagnetic fields

Electromagnetic fields are created during the operation of pumps with frequency converter. Interference of electronic devices may be the result. The result may be a device malfunction, which can result in damage to the health or even death, e.g. of persons carrying implanted active or passive medical devices. Therefore, during operation the presence of any persons e.g. with cardiac pacemakers in the vicinity of the unit/pump should be prohibited. With magnetic or electronic data media, the loss of data is possible.

8.5 Decommissioning

The pump must be decommissioned before conducting maintenance, repair or dismantling work on the system.



DANGER! Risk of fatal injury!

There is a risk of fatal injury from electric shock when working on electrical equipment.

- **Have work on the electrical part of the pump carried out only by a qualified electrician as a basic principle.**
- **Before starting any maintenance and repair work on the system, disconnect the pump from the power supply, and make sure it cannot be switched back on by unauthorised persons.**
- **Work on the pump may only be started after 5 minutes have elapsed due to the dangerous residual contact voltage.**
- **Check whether all connections (including potential-free contacts) are voltage-free.**
- **The pump may still be live even in voltage-free state. The drive rotor induces a dangerous contact voltage at the motor contacts.**
Close the shut-off devices in front of and behind the pump.
- **If the control module/cable is damaged, do not operate the pump.**



WARNING! Risk of burns!

Touching the pump can cause burns!

Depending on the pump or system operating conditions (fluid temperature), the entire pump can become very hot.

Allow the installation and pump to cool to room temperature.

9 Maintenance

Before carrying out maintenance /cleaning and repair work, observe chapters 8.4 "Operation", 8.5 "Decommissioning" and 9.1 "Dismantling/Installation".

The safety instructions in Chapter 2.6 and Chapter 7 must be complied with.

After completing maintenance and repair work, install and connect the pump according to chapter 7 "Installation and electrical connection". Switch on the pump according to chapter 8 "Commissioning".

9.1 Dismantling/Installation



WARNING! Risk of injury and damage to property!

Incorrect dismantling/installation can lead to injuries and damage to property.

- **Touching the pump can cause burns!**
Depending on the pump or system operating conditions (fluid temperature), the entire pump can become very hot.
- **At high fluid temperatures and system pressures there is risk of scalding due to escaping hot fluid.**
Before dismantling the motor, close the existing shut-off devices on both sides of the pump, allow the pump to cool down to room temperature, and drain the isolated branch of the system. If no shut-off devices are fitted, drain the system.
- **Observe the manufacturer's information and safety data sheets on possible additives in the unit.**
- **Risk of injury due to the pump falling when the threaded pipe union has been undone.** Comply with national regulations for accident prevention and also with the operator's internal works, company and safety regulations. If necessary, wear protective clothing and equipment!
- **It is not permitted to remove the control module!**



WARNING! Danger due to magnetic field!

Inside the machine there is always a magnetic field that can cause injury and damage to property in the event of incorrect dismantling.

- **It is not permitted to remove the rotor unit (comprising the separating can, bearing plate, rotor and impeller) from the motor housing!**
- **If the unit consisting of impeller, bearing plate, rotor, and separating can is pulled out of the motor without permission, persons with medical aids, such as cardiac pacemakers, insulin pumps, hearing aids, implants or similar are at risk. For such persons, a professional medical assessment is always necessary.**
- **Electronic devices may be impaired functionally or damaged by the magnetic field of the rotor.**

In assembled condition, the rotor's magnetic field is guided in the motor's iron core. There is therefore no harmful magnetic field outside the machine.



DANGER! Risk of fatal electrical shock!

If the upper part of the control module is dismantled improperly, a potentially fatal shock voltage may be present at the electronics on the inside.

If you wish to move the control module to another position, the motor (motor housing and control module) must not be completely removed from the rotor unit. The motor can be rotated to the desired position (see Fig. 2a for the permissible installation positions).



NOTE: Generally turn the motor head before the installation is filled.

- The release the motor, undo 4 internal hexagon head screws.
- After rotating the motor, tighten the 4 internal hexagon head screws again crosswise.
- For the commissioning of the pump, see Chapter 8.

10 Faults, causes and remedies

For faults, causes and remedies see tables 10 and 10.1.

Have faults remedied by qualified personnel only! Follow the safety instructions in chapter 9!

Faults	Causes	Remedy
Pump is not running although the current entry is switched on.	Electrical fuse defective.	Check fuses.
	Pump has no voltage.	Reconnect the voltage.
Pump is noisy.	Cavitation due to insufficient suction pressure.	Increase the system suction pressure <u>within the permissible range.</u>
		Check the delivery head and set it to a lower height if necessary.

Table 10: Faults with external interference sources

Faults	Causes	Performance of the pump/remedy	Description
Mains undervoltage	Mains overloaded	Switch off and restart the motor.	In the event of overvoltage or undervoltage, the motor is switched off. It starts automatically when the voltage is within the valid range once again. SSM relay is active.
Mains overvoltage	Faulty supply by the energy provider	Switch off and restart the motor.	
Motor blocking	e.g. due to deposits	Motor restarts after a delay. After 5 unsuccessful starts the motor is switched off permanently.	If the motor is blocked, a maximum of 5 restarts are initiated at 30 second intervals. If the motor is still blocked, it is switched off permanently. This can only happen if the power is disconnected for longer than 30 seconds and then switched on again. The unblocking programme runs during every start-up procedure. The SSM relay is active as long as the internal error counter is not ZERO.
Synchronous run defective	High level of friction, motor control not okay	If the motor's rotating field is not synchronised, the pump tries to restart every 5 seconds.	In the event of a defective synchronous run the motor is shut off. A restart is initiated after 5 seconds. The pump starts automatically once the rotating field is synchronised.
Motor overload	Deposits in the pump	The motor stops when overload has been detected and restarts after a delay.	When the motor's power limit has been reached, the motor stops. A restart is initiated after 30 seconds. The pump starts automatically when the motor's power is below the limit.

Faults	Causes	Performance of the pump/remedy	Description
Short-circuit	Motor/module defective	The motor stops from a short circuit and restarts after a delay. After 25 unsuccessful starts the motor is switched off permanently.	After a short circuit the motor is shut off. It is reactivated after 1 seconds. After 25 short circuits it is shut off permanently. This can only be reset if the power is disconnected for >30 seconds. The SSM relay is active as long as the internal error counter is not ZERO.
Contact/winding error	Contact problems with the motor. Motor winding motor or plug is damaged.	Motor restarts after a delay. After 5 unsuccessful starts the motor is switched off permanently.	If contact between the motor and module fails, the motor is shut off. A restart is initiated after 30 seconds. After it has been switched off five times the motor is shut off permanently. This can only be reset if the power is disconnected for >30 seconds. The SSM relay is active as long as the internal error counter is not ZERO.
Dry run	Venting faulty	Motor restarts after a delay.	After being exposed to dry-running conditions for a certain time frame the motor is shut off. It restarts after a delay of 30 seconds. The pump runs automatically under normal conditions when dry running is longer present.
Excess module temperature	Limited air supply to the heat sink of the module	Operation of the pump outside the permissible temperature limits.	If the interior temperature of the module increases excessively, the pump switches off and reports a fault. A restart is initiated after 30 seconds. After it has been switched off five times the motor is shut off permanently. This can only be reset if the power is disconnected for >30 seconds. The SSM relay is active as long as the internal error counter is not ZERO.

Table 10: Faults on the pump

If the operating fault cannot be remedied, please consult a specialist technician or the nearest Wilocustomer service point or representative.

10.1 Fault signals

Faults always result in the activation of the “collective fault signal” (SSM) via a relay.

The response of the pump depends on the type of fault (see process diagram and table 10.1).

Process diagram of the temporal response of the pump in the event of a fault

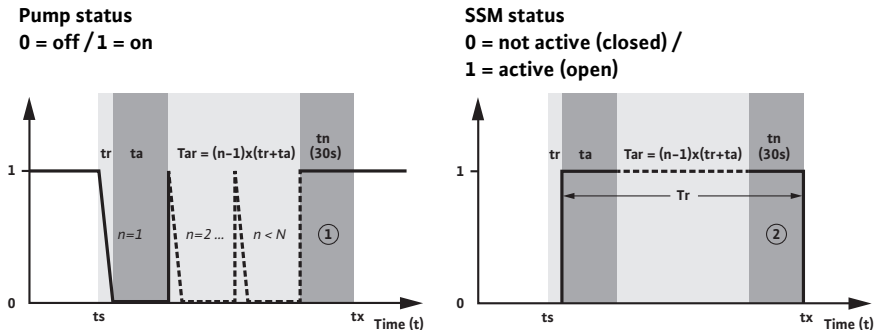

Explanations regarding the fault process

(t_s) Fault present:

Start time of the fault process

(t_r) Response time:

Time until the fault is detected

(t_a) Delay time:

Time until the pump starts again; for restart times see table 10.2

(n) Occurring fault:

Number of repeated faults

(T_{ar}) Time for restart attempts:

Time resulting from repetitions of the restart for as long as the fault is present. “ T_{ar} ” can be 0 seconds if the fault only occurs once ($n=1$).

(N) Allowed number of faults:

If there is a restricted fault rate, the counter is only reset if a fault no longer occurs within 30 seconds (t_n). Otherwise the mains voltage must be disconnected for >30 seconds in order to restart the pump.

Auto reset:

Yes: the number of allowed faults is unrestricted. The software ensures a restart of the pump after the delay time.

No: the number of allowed faults is restricted. The pump can only be restarted if the mains voltage is disconnected for >30 seconds.

(T_r) Total duration of SSM activity:

Duration of the operating fault of the pump; the SSM contact is open

① Waiting time to check whether a new fault follows.

② Pump runs again in the normal operating mode.

(t_x) Fault is remedied; SSM is closed

Response of the pump in the event of a fault

Fault	Response time (tr)	Delay time (ta)	Permissible number of faults (N)	Auto reset	Waiting time (SSM is active) (tn)	SSM
Mains undervoltage	≤ 100 ms	≤ 20 ms	no restrictions	yes	30 s	open Response time ≤ 1.35 s
Mains overvoltage	≤ 100 ms	≤ 20 ms	no restrictions	yes	30 s	open
Motor blocking	≤ 10 s	30 s	5	no	30 s	open
Defective synchronous run	≤ 10 s	≤ 5 s	no restrictions	yes	30 s	open
Motor overload	60 s	30 s	no restrictions	yes	30 s	open
Short circuit/earth leakage	< 6 μs	1 s	25	no	30 s	open
Contact/winding error	< 10 s	30 s	5	no	30 s	open
Dry run	< 60 s	30 s	no restrictions	yes	30 s	open
Excess module temperature	< 1 s	30 s	5	no	30 s	open

Table 10.1: Response of the pump in the event of a fault

10.2 Restart times of the pump

Start-up time for:	
Dp-c, power switched on	
0 to min Dp-c	4 s
0 to max Dp-c	6 s
Dp-v, power switched on	
0 to min Dp-v	4 s
0 to max Dp-v	5 s
Control input "Analogue In 0...10V"	
0-10V ON: 0 to n _{min}	1 (2) s
0-10V ON: 0 to n _{max}	2 (3) s
n _{min} to n _{max}	2 s

() Start time when power is switched on

Table 10.2: Restart times of the pump

11 Spare parts

No spare parts are available for the Yonos ECO BMS pumps. In the event of damage, the entire pump should be replaced.

12 Disposal

Information on the collection of used electrical and electronic products

Proper disposal and appropriate recycling of this product prevents damage to the environment and dangers to your personal health.

When dismantling and disposing of the pump, do not fail to observe the warnings in Chapter 9.1!



NOTICE

Disposal in domestic waste is forbidden!

In the European Union, this symbol can appear on the product, the packaging or the accompanying documentation. It means that the electrical and electronic products in question must not be disposed of along with domestic waste.

To ensure proper handling, recycling and disposal of the used products in question, please note the following points:

- Only hand over these products at designated, certified collecting points.
- Observe the locally applicable regulations!

Please consult your local municipality, the nearest waste disposal site, or the dealer who sold the product to you for information on proper disposal. For further information on recycling, go to www.wilo-recycling.com.

Subject to change without prior notice

EU/EG KONFORMITÄTSERKLÄRUNG
EU/EC DECLARATION OF CONFORMITY
DECLARATION DE CONFORMITE UE/CE

Als Hersteller erklären wir hiermit, dass die Nassläufer-Umwälzpumpen der Baureihe
We, the manufacturer, declare that these glandless circulating pump types of the series
Nous, fabricant, déclarons que les types de circulateurs de la série

Yonos ECO ... BMS

(Die Seriennummer ist auf dem Typenschild des Produktes nach Punkten b) & c) von §1.7.4.2 und §1.7.3 des Anhanges I der Maschinenrichtlinie angegeben. / The serial number is marked on the product site plate according to points b) & c) of §1.7.4.2 and §1.7.3 of the annex I of the Machinery directive. / Le numéro de série est inscrit sur la plaque signalétique du produit en accord avec les points b) & c) du §1.7.4.2 et du §1.7.3 de l'annexe I de la Directive Machines.)

in der gelieferten Ausführung folgenden einschlägigen Bestimmungen entsprechen :
In their delivered state comply with the following relevant directives :
dans leur état de livraison sont conformes aux dispositions des directives suivantes :

_ Maschinenrichtlinie 2006/42/EG

_ Machinery 2006/42/EC

_ Machines 2006/42/CE

und gemäss Anhang 1, §1.5.1, werden die Schutzziele der Niederspannungsrichtlinie 2014/35/EU ab 20 April 2016 eingehalten
and according to the annex 1, §1.5.1, comply with the safety objectives of the Low Voltage Directive 2014/35/EU from April 20th 2016
et, suivant l'annexe 1, §1.5.1, respectent les objectifs de sécurité de la Directive Basse Tension 2014/35/UE à partir du 20/04/2016

_ Elektromagnetische Verträglichkeit-Richtlinie 2014/30/EU ab 20 April 2016

_ Electromagnetic compatibility 2014/30/EU from April 20th 2016

_ Compabilité électromagnétique 2014/30/UE à partir du 20 avril 2016

_ Richtlinie energieverbrauchsrelevanter Produkte 2009/125/EG

_ Energy-related products 2009/125/EC

_ Produits liés à l'énergie 2009/125/CE

Nach den Ökodesign-Anforderungen der Verordnung 641/2009 für Nassläufer-Umwälzpumpen, die durch die Verordnung 622/2012 geändert wird
This applies according to eco-design requirements of the regulation 641/2009 for glandless circulators amended by the regulation 622/2012
suivant les exigences d'éco-conception du règlement 641/2009 pour les circulateurs, amendé par le règlement 622/2012

und entsprechender nationaler Gesetzgebung,
and with the relevant national legislation,
et aux législations nationales les transposant,

sowie auch den Bestimmungen zu folgenden harmonisierten europäischen Normen :
comply also with the following relevant harmonized European standards :
sont également conformes aux dispositions des normes européennes harmonisées suivantes :

EN 809+A1

EN 60335-2-51

EN 16297-1
EN 16297-2

EN 61800-3+A1:2012

Bevollmächtigter für die Zusammenstellung der technischen Unterlagen ist:

Person authorized to compile the technical file is :

Personne autorisée à constituer le dossier technique est :

Dortmund,

Digital unterschrieben
von
holger.herchenhein@wil
o.com

Datum: 2016.06.15
08:42:00 +02'00'

H. HERCHENHEIN
Senior Vice President - Group ITQ

Division HVAC
Quality Manager - PBU Circulating Pumps
WILO SE
Nortkirchenstraße 100
D-44263 Dortmund

wilo

WILO SE
Nortkirchenstraße 100
44263 Dortmund - Germany

N°2118033.02 (CE-A-S n°4146382)

<p align="center">(BG) - Български език ДЕКЛАРАЦИЯ ЗА СЪОТГЕТВИЕ ЕО</p> <p>WILO SE декларира, че продуктите посочени в настоящата декларация съответстват на разпоредбите на следните европейски директиви и приелите ги национални законодателства:</p> <p>Машини 2006/42/ЕО; Електромагнитна съвместимост 2004/108/ЕО; Продукти, свързани с енергопотреблението 2009/125/ЕО</p> <p>както и на хармонизираните европейски стандарти, упоменати на предишната страница.</p>	<p align="center">(CS) - Čeština ES PROHLÁŠENÍ O SHODĚ</p> <p>WILO SE prohlašuje, že výrobky uvedené v tomto prohlášení odpovídají ustanovením níže uvedených evropských směrnic a národním právním předpisům, které je přijímají:</p> <p>Stroje 2006/42/ES; Elektromagnetická Kompatibilita 2004/108/ES; Výrobků spojených se spotřebou energie 2009/125/ES</p> <p>a rovněž splňují požadavky harmonizovaných evropských norem uvedených na předcházející stránce.</p>
<p align="center">(DA) - Dansk EF-OVERENSSTEMMELSESERKLÆRING</p> <p>WILO SE erklærer, at produkterne, som beskrives i denne erklæring, er i overensstemmelse med bestemmelserne i følgende europæiske direktiver, samt de nationale lovgivninger, der gennemfører dem:</p> <p>Maskiner 2006/42/EF; Elektromagnetisk Kompatibilitet 2004/108/EF; Energirelaterede produkter 2009/125/EF</p> <p>De er ligeledes i overensstemmelse med de harmoniserede europæiske standarder, der er anført på forrige side.</p>	<p align="center">(EL) - Ελληνικά ΔΗΛΩΣΗ ΣΥΜΜΟΡΦΩΣΗΣ ΕΚ</p> <p>WILO SE δηλώνει ότι τα προϊόντα που ορίζονται στην παρούσα ευρωπαϊκά δηλωσή είναι σύμφωνα με τις διατάξεις των παρακάτω οδηγιών και τις εθνικές νομοθεσίες στις οποίες έχει μεταφερθεί:</p> <p>Μηχανήματα 2006/42/ΕΚ; Ηλεκτρομαγνητικής συμβατότητας 2004/108/ΕΚ; Συνδεόμενα με την ενέργεια προϊόντα 2009/125/ΕΚ</p> <p>και επίσης με τα εξής εναρμονισμένα ευρωπαϊκά πρότυπα που αναφέρονται στην προηγούμενη σελίδα.</p>
<p align="center">(ES) - Español DECLARACIÓN CE DE CONFORMIDAD</p> <p>WILO SE declara que los productos citados en la presente declaración están conformes con las disposiciones de las siguientes directivas europeas y con las legislaciones nacionales que les son aplicables:</p> <p>Máquinas 2006/42/CE; Compatibilidad Electromagnética 2004/108/CE; Productos relacionados con la energía 2009/125/CE</p> <p>Y igualmente están conformes con las disposiciones de las normas europeas armonizadas citadas en la página anterior.</p>	<p align="center">(ET) - Eesti keel EÜ VASTAVUSDEKLARATSIOONI</p> <p>WILO SE kinnitab, et selles vastavustunnistuses kirjeldatud tooted on kooskõlas alljärgnevat Euroopa direktiivide sätetega ning riiklike seadusandlustega, mis nimetatud direktiivid üle on võtnud:</p> <p>Masinaid 2006/42/EÜ; Elektromagnetilist Ühilduvust 2004/108/EÜ; Energiamaiduga toodete 2009/125/EÜ</p> <p>Samuti on tooted kooskõlas eelmisel leheküljel ära toodud harmoneeritud Euroopa standarditega.</p>
<p align="center">(FI) - Suomen kieli EY-VAATIMUSTENMUKAISUUSVAKUUTUS</p> <p>WILO SE vakuuttaa, että tässä vakuutuksessa kuvutat tuotteet ovat seuraavien eurooppalaisten direktiivien määräysten sekä niihin sovellettavien kansallisten lakiasetusten mukaisia:</p> <p>Koneet 2006/42/EY; Sähkömagneettinen Yhteensopivuus 2004/108/EY; Energiaan liittyvien tuotteiden 2009/125/EY</p> <p>Lisäksi ne ovat seuraavien edellisellä sivulla mainittujen yhdenmukaistettujen eurooppalaisten normien mukaisia.</p>	<p align="center">(HR) - Hrvatski EZ IZJAVA O SUKLADNOSTI</p> <p>WILO SE izjavljuje da su proizvodi navedeni u ovoj izjavi u skladu sa sljedećim prihvaćenim europskim direktivama i nacionalnim zakonima:</p> <p>EZ smjernica o strojevima 2006/42/EZ; Elektromagnetna kompatibilnost - smjernica 2004/108/EZ; Smjernica za proizvode relevantne u pogledu potrošnje energije 2009/125/EZ</p> <p>i usklađenim europskim normama navedenim na prethodnoj stranici.</p>
<p align="center">(HU) - Magyar EK-MEGFELELŐSÉGI NYILATKOZAT</p> <p>WILO SE kijelenti, hogy a jelen megfelelőségi nyilatkozatban megjelölt termékek megfelelnek a következők európai irányelvek előírásainak, valamint azok nemzeti jogrendszer áttüztetett rendelkezéseinek:</p> <p>Gépek 2006/42/EK; Elektromágneses összeférhetőségre 2004/108/EK; Energiával kapcsolatos termékek 2009/125/EK</p> <p>valamint az előző oldalon szereplő, harmonizált európai szabványoknak.</p>	<p align="center">(IT) - Italiano DICHIARAZIONE CE DI CONFORMITÀ</p> <p>WILO SE dichiara che i prodotti descritti nella presente dichiarazione sono conformi alle disposizioni delle seguenti direttive europee nonché alle legislazioni nazionali che le traspongono:</p> <p>Macchine 2006/42/CE; Compatibilità Elettromagnetica 2004/108/CE; Prodotti connessi all'energia 2009/125/CE</p> <p>E sono pure conformi alle disposizioni delle norme europee armonizzate citate a pagina precedente.</p>
<p align="center">(LT) - Lietuvių kalba EB ATITIKTIES DEKLARACIJA</p> <p>WILO SE pareiškia, kad šioje deklaracijoje nurodyti gaminiai atitinka šių Europos direktyvų ir jas perkeliančių nacionalinių įstatymų nuostatas:</p> <p>Mašinos 2006/42/EB; Elektromagnetinis Suderinamumas 2004/108/EB; Energija susijusiems gaminiams 2009/125/EB</p> <p>ir taip pat harmonizuotas Europos normas, kurios buvo cituotos ankstesniame puslapyje.</p>	<p align="center">(LV) - Latviešu valoda EK ATBILSTĪBAS DEKLARĀCIJU</p> <p>WILO SE deklarē, ka izstrādājumi, kas ir nosaukti šajā deklarācijā, atbilst šeit uzskaitīto Eiropas direktīvu nosacījumiem, kā arī atsevišķu valstu likumiem, kuros tie ir ietverti:</p> <p>Mašīnas 2006/42/EK; Elektromagnētiskās Saderības 2004/108/EK; Energiju saistītiem ražojumiem 2009/125/EK</p> <p>un saskaņotajiem Eiropas standartiem, kas minēti iepriekšējā lappusē.</p>
<p align="center">(MT) - Malti DIKJARAZZJONI KE TA' KONFORMITÀ</p> <p>WILO SE jiddikjara li i-prodotti speċifikati f'din id-dikjarazzjoni huma konformi mad-direttivi Ewropej li jsegwu u mal-legislazzjonijiet nazzjonali li japplikawhom:</p> <p>Makinarju 2006/42/KE; Kompatibilità Elettromanjetika 2004/108/KE; Prodotti relatati mal-enerġija 2009/125/KE</p> <p>kif ukoll man-normi Ewropej armonizzati li jsegwu imsemmija fil-paġna preċedenti.</p>	<p align="center">(NL) - Nederlands EG-VERKLARING VAN OVERENSTEMMING</p> <p>WILO SE verklaart dat de in deze verklaring vermelde producten voldoen aan de bepalingen van de volgende Europese richtlijnen evenals aan de nationale wetgevingen waarin deze bepalingen zijn overgenomen:</p> <p>Machines 2006/42/EG; Elektromagnetische Compatibiliteit 2004/108/EG; Energiegerelateerde producten 2009/125/EG</p> <p>De producten voldoen eveneens aan de geharmoniseerde Europese normen die op de vorige pagina worden genoemd.</p>

<p align="center">(NO) - Norsk EU-OVERENSSTEMMELSESERKLÆING</p> <p>WILO SE erklærer at produktene nevnt i denne erklæringen er i samsvar med følgende europeiske direktiver og nasjonale lover:</p> <p>EG-Maskindirektiv 2006/42/EG ; EG-EMV-Elektromagnetisk kompatibilitet 2004/108/EG ; Direktiv energirelaterte produkter 2009/125/EF</p> <p>og harmoniserte europeiske standarder nevnt på forrige side.</p>	<p align="center">(PL) - Polski DEKLARACJA ZGODNOŚCI WE</p> <p>WILO SE oświadcza, że produkty wymienione w niniejszej deklaracji są zgodne z postanowieniami następujących dyrektyw europejskich i transponującymi je przepisami prawa krajowego:</p> <p>Maszyn 2006/42/WE ; Kompatybilności Elektromagnetycznej 2004/108/WE ; Produktów związanych z energią 2009/125/WE</p> <p>oraz z następującymi normami europejskich zharmonizowanymi podanymi na poprzedniej stronie.</p>
<p align="center">(PT) - Português DECLARAÇÃO CE DE CONFORMIDADE</p> <p>WILO SE declara que os materiais designados na presente declaração obedecem às disposições das diretivas europeias e às legislações nacionais que as transcrevem :</p> <p>Máquinas 2006/42/CE ; Compatibilidade Electromagnética 2004/108/CE ; Produtos relacionados com o consumo de energia 2009/125/CE</p> <p>E obedecem também às normas europeias harmonizadas citadas na página precedente.</p>	<p align="center">(RO) - Română DECLARAȚIE DE CONFORMITATE CE</p> <p>WILO SE declară că produsele citate în prezenta declarație sunt conforme cu dispozițiile directivelor europene următoare și cu legislațiile naționale care le transpun :</p> <p>Mașini 2006/42/CE ; Compatibilitate Electromagnetică 2004/108/CE ; Produselelor cu impact energetic 2009/125/CE</p> <p>și, de asemenea, sunt conforme cu normele europene armonizate citate în pagina precedentă.</p>
<p align="center">(RU) - русский язык Декларация о соответствии Европейским нормам</p> <p>WILO SE заявляет, что продукты, перечисленные в данной декларации о соответствии, отвечают следующим европейским директивам и национальным предписаниям:</p> <p>Директива ЕС по машинному оборудованию 2006/42/ЕС ; Директива ЕС по электромагнитной совместимости 2004/108/ЕС ; Директива о продукции, связанной с энергопотреблением 2009/125/ЕС</p> <p>и гармонизированным европейским стандартам, упомянутым на предыдущей странице.</p>	<p align="center">(SK) - Slovenčina ES VYHLÁSENIE O ZHODE</p> <p>WILO SE čestne prehlasuje, že výrobky ktoré sú predmetom tejto deklarácie, sú v súlade s požiadavkami nasledujúcich európskych direktív a odpovedajúcich národných legislatívnych predpisov:</p> <p>Strojových zariadeniach 2006/42/ES ; Elektromagnetickú Kompatibilitu 2004/108/ES ; Energeticky významných výrobkov 2009/125/ES</p> <p>ako aj s harmonizovanými európskych normami uvedenými na predchádzajúcej strane.</p>
<p align="center">(SL) - Slovenščina ES-IZJAVA O SKLADNOSTI</p> <p>WILO SE izjavlja, da so izdelki, navedeni v tej izjavi, v skladu z določili naslednjih evropskih direktiv in z nacionalnimi zakonodajami, ki jih vsebujejo:</p> <p>Stroji 2006/42/ES ; Elektromagnetno Zdržljivostjo 2004/108/ES ; Izdelkov, povezanih z energijo 2009/125/ES</p> <p>pa tudi z usklajenimi evropskih standardi, navedenimi na prejšnji strani.</p>	<p align="center">(SV) - Svenska EG-FÖRSÄKRAN OM ÖVERENSSTÄMMELSE</p> <p>WILO SE intygar att materialet som beskrivs i följande intyg överensstämmer med bestämmelserna i följande europeiska direktiv och nationella lagstiftningar som inför dem:</p> <p>Maskiner 2006/42/EG ; Elektromagnetisk Kompatibilitet 2004/108/EG ; Energirelaterade produkter 2009/125/EG</p> <p>Det överensstämmer även med följande harmoniserade europeiska standarder som nämnts på den föregående sidan.</p>
<p align="center">(TR) - Türkçe CE UYGUNLUK TEYİD BELGESİ</p> <p>WILO SEbu belgede belirtilen ürünlerin aşağıdaki Avrupa yönetmeliklerine ve ulusal kanunlara uygun olduğunu beyan etmektedir:</p> <p>Makine Yönetmeliği 2006/42/AT ; Elektromanyetik Uyumluluk Yönetmeliği 2004/108/AT ; Eko Tasarım Yönetmeliği 2009/125/AT</p> <p>ve önceki sayfada belirtilen uyumlaştırılmış Avrupa standartlarına.</p>	

wilo



Pioneering for You