

Wilo-SiFire Easy



de Einbau- und Betriebsanleitung
en Installation and operating instructions

fr Notice de montage et de mise en service

Fig. 1:

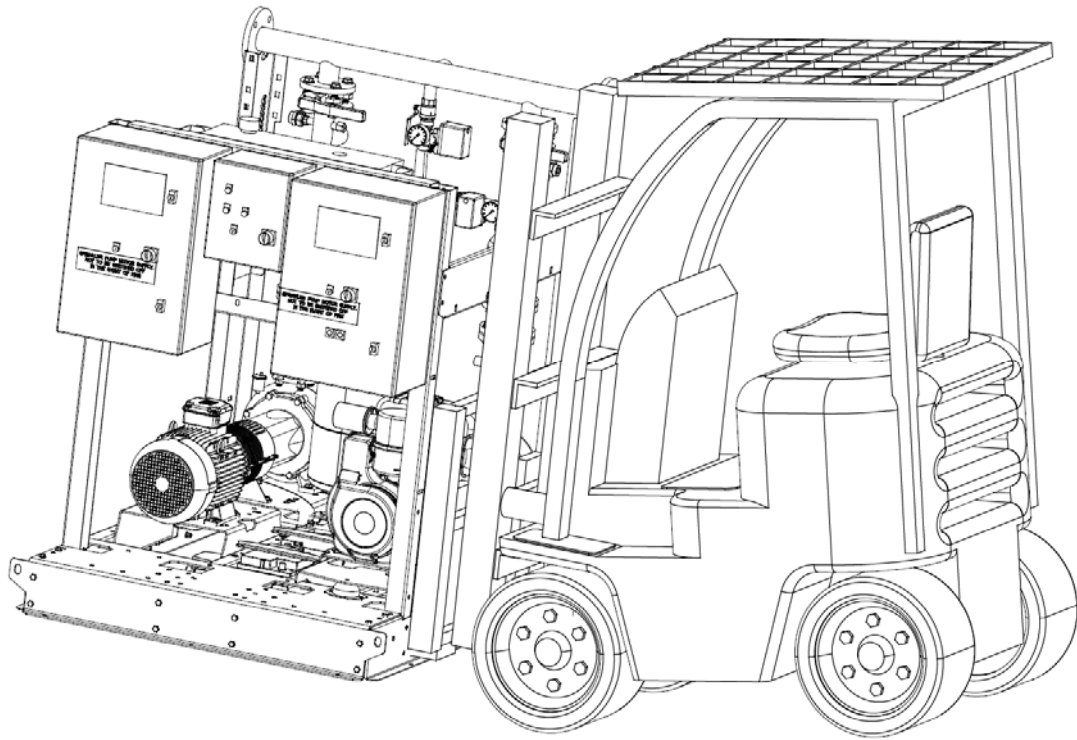

Fig. 2a:

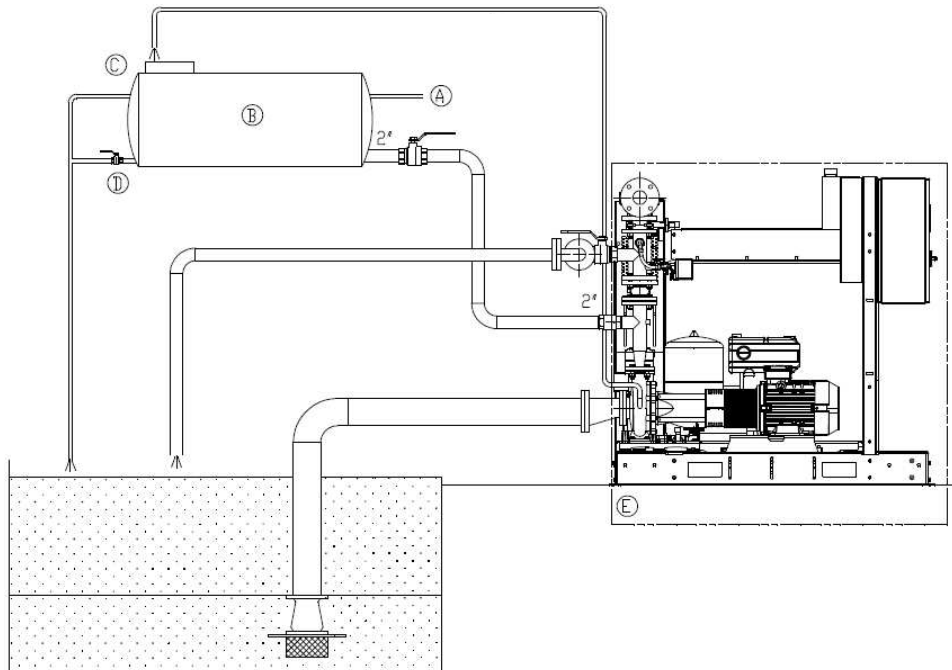

Fig. 2b:

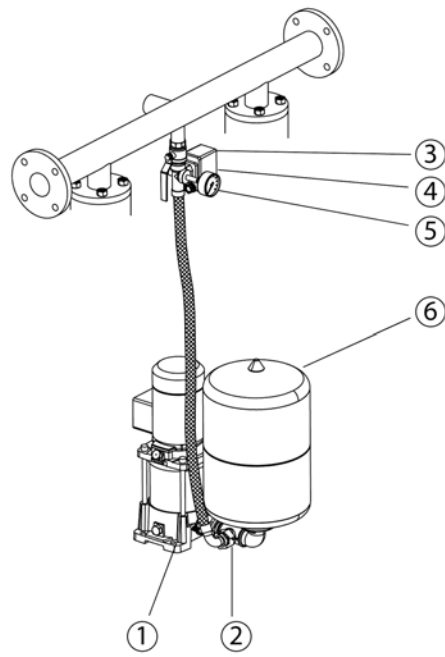

Fig. 3:

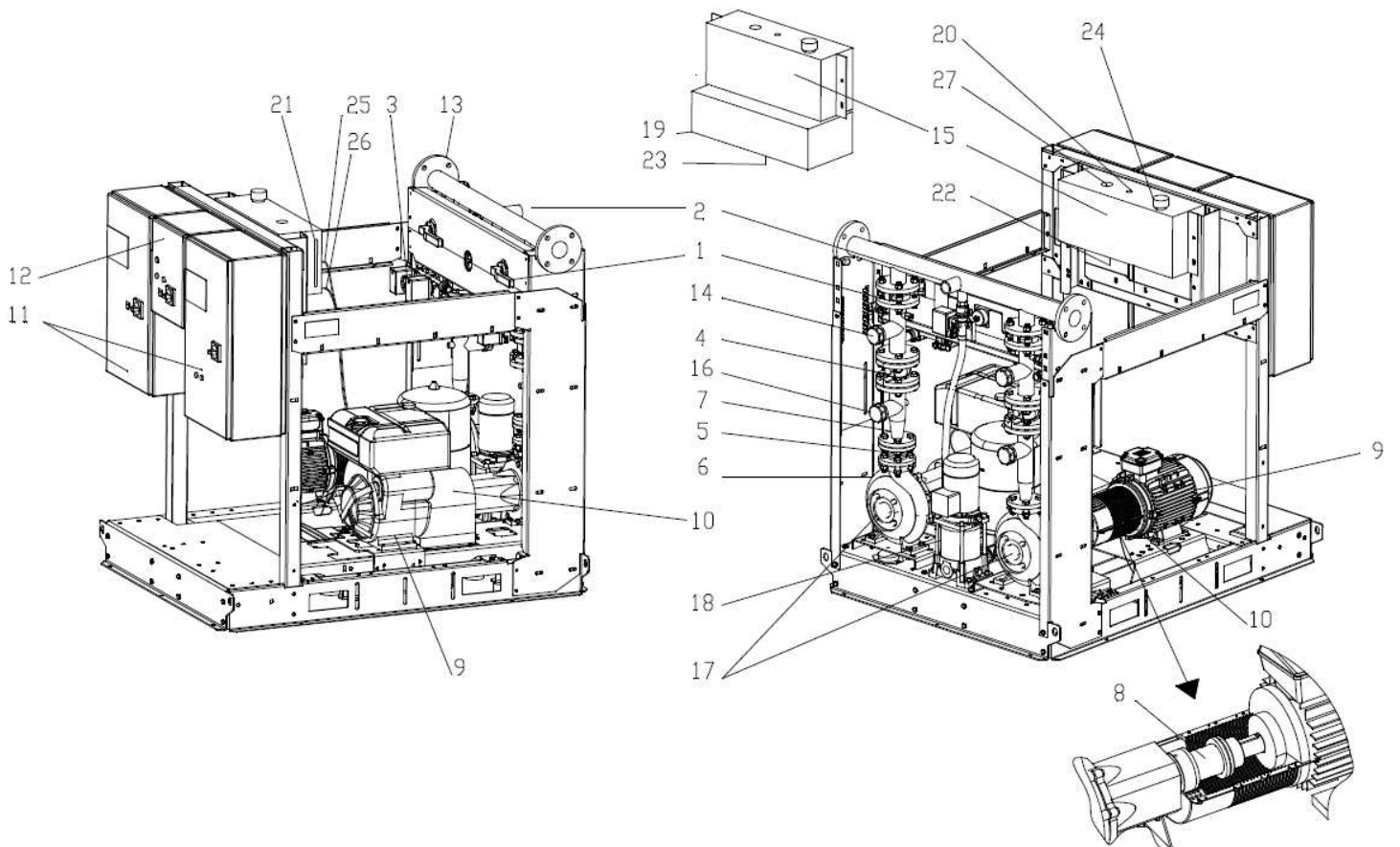

Fig. 4:

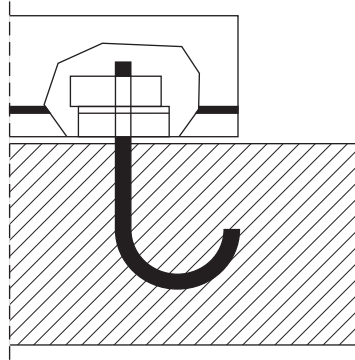

Fig. 5:

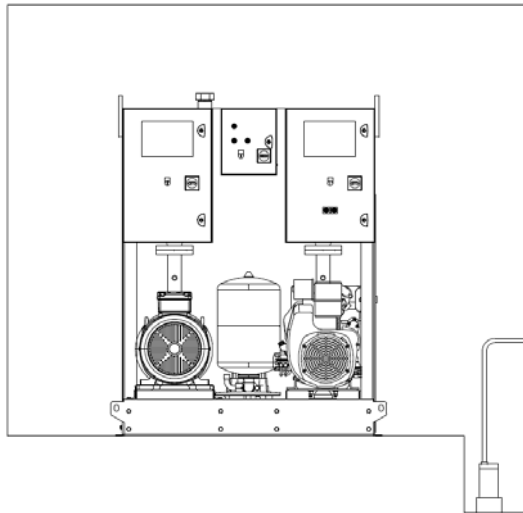

Fig. 6a:

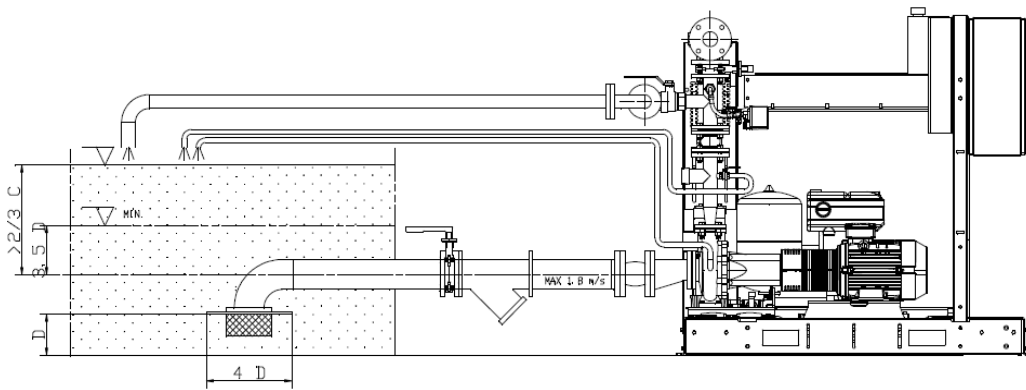

Fig. 6b:

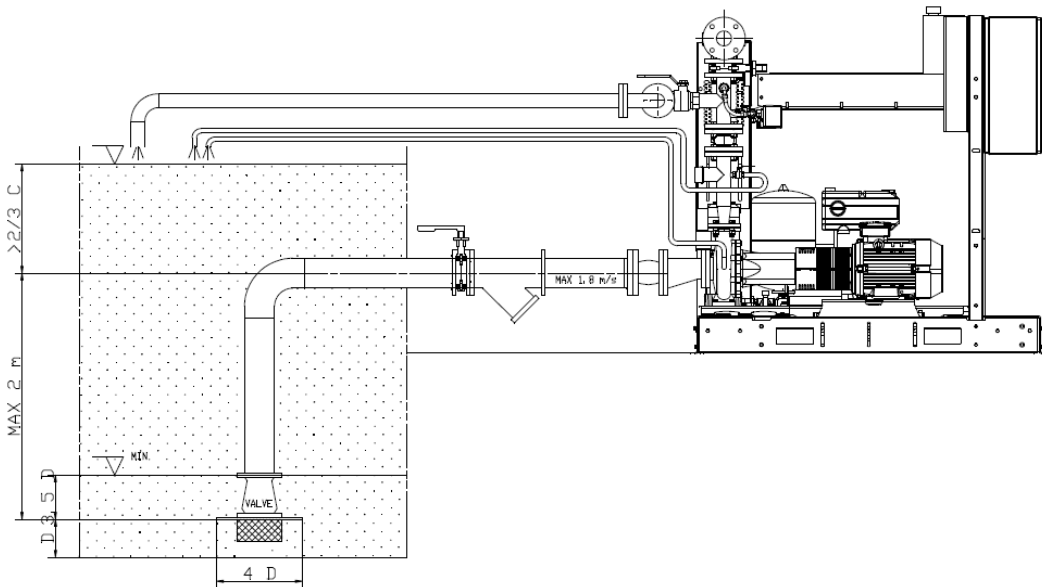

Fig. 7:

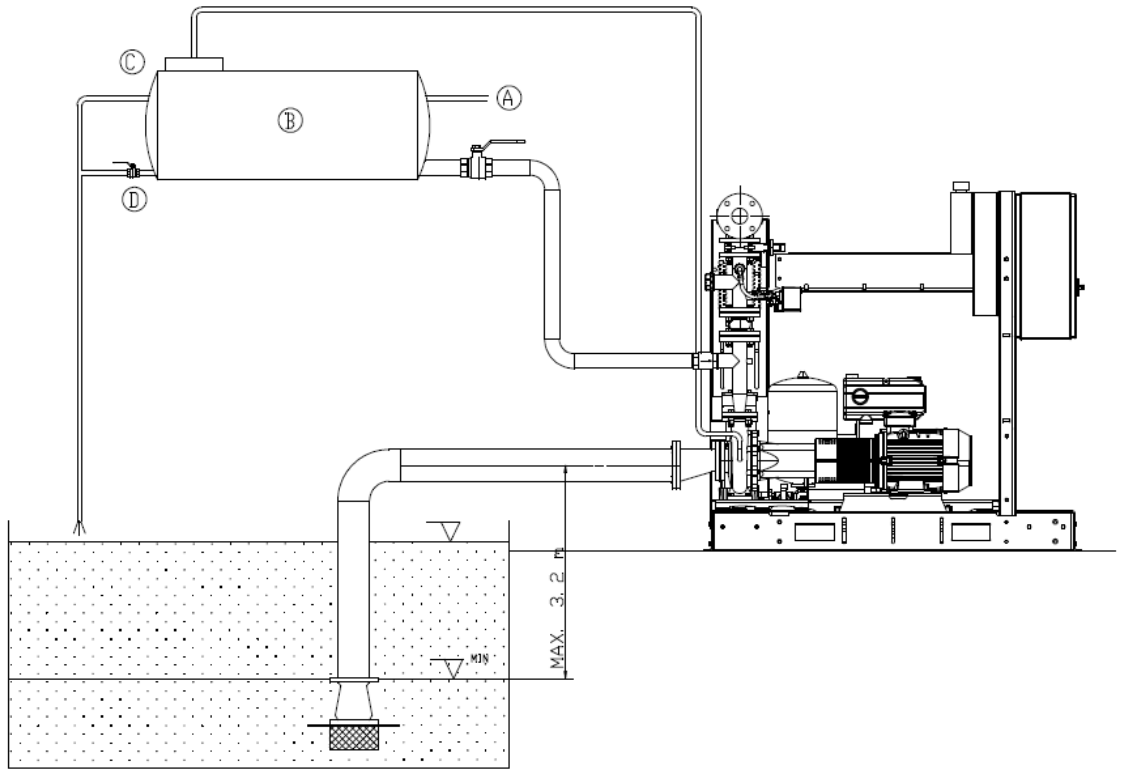

Fig. 8:

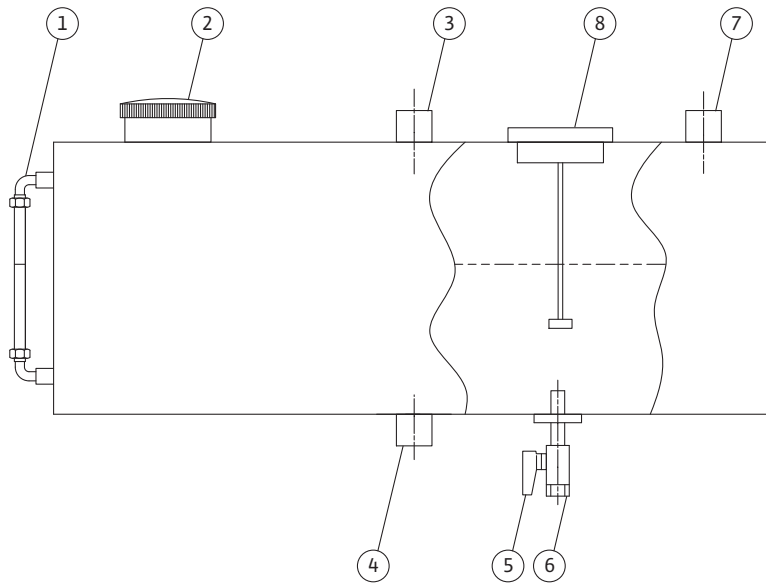

Fig. 9a:

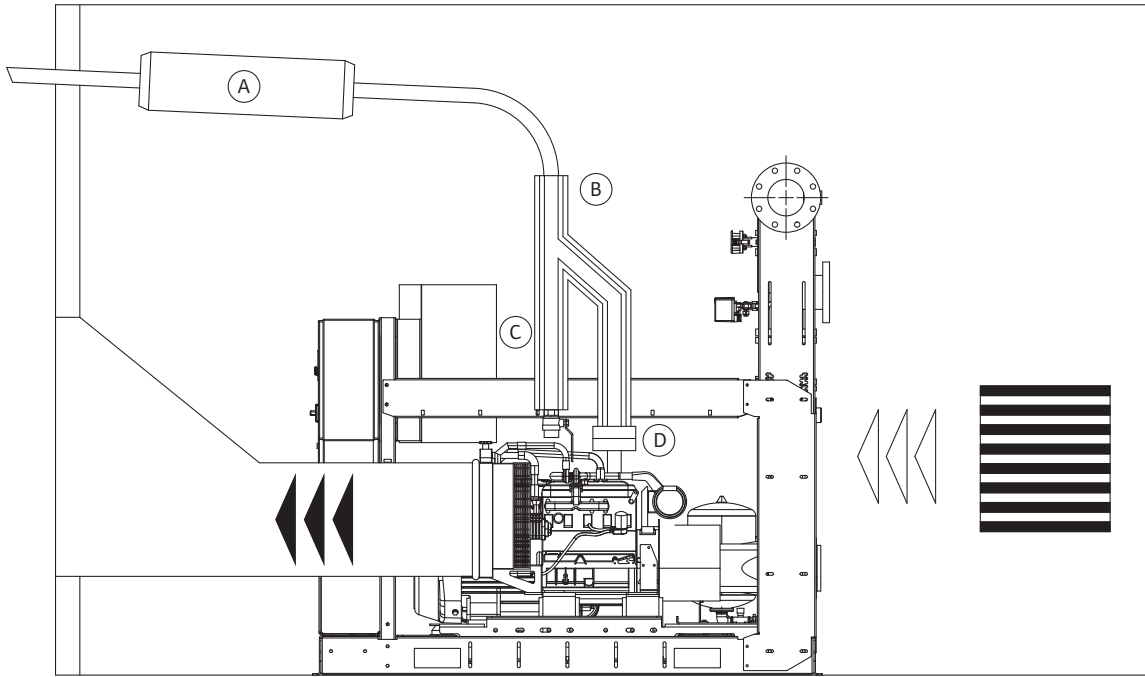

Fig. 9b:

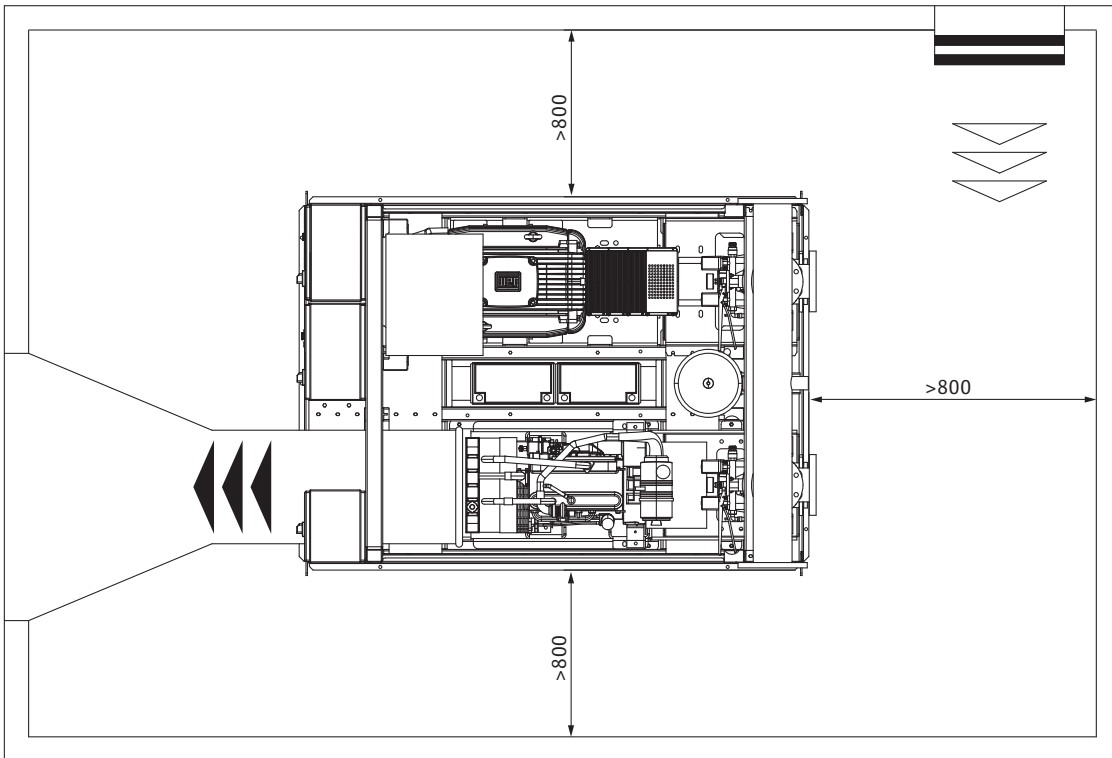

Fig. 9a: (variant)

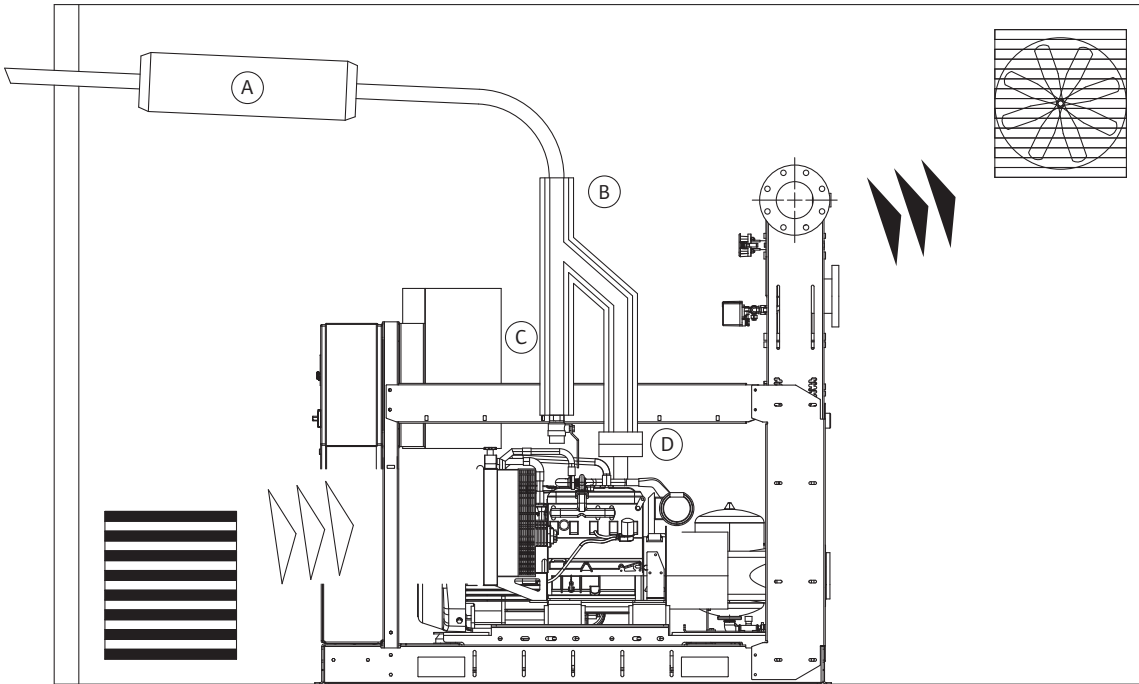

Fig. 9b: (variant)

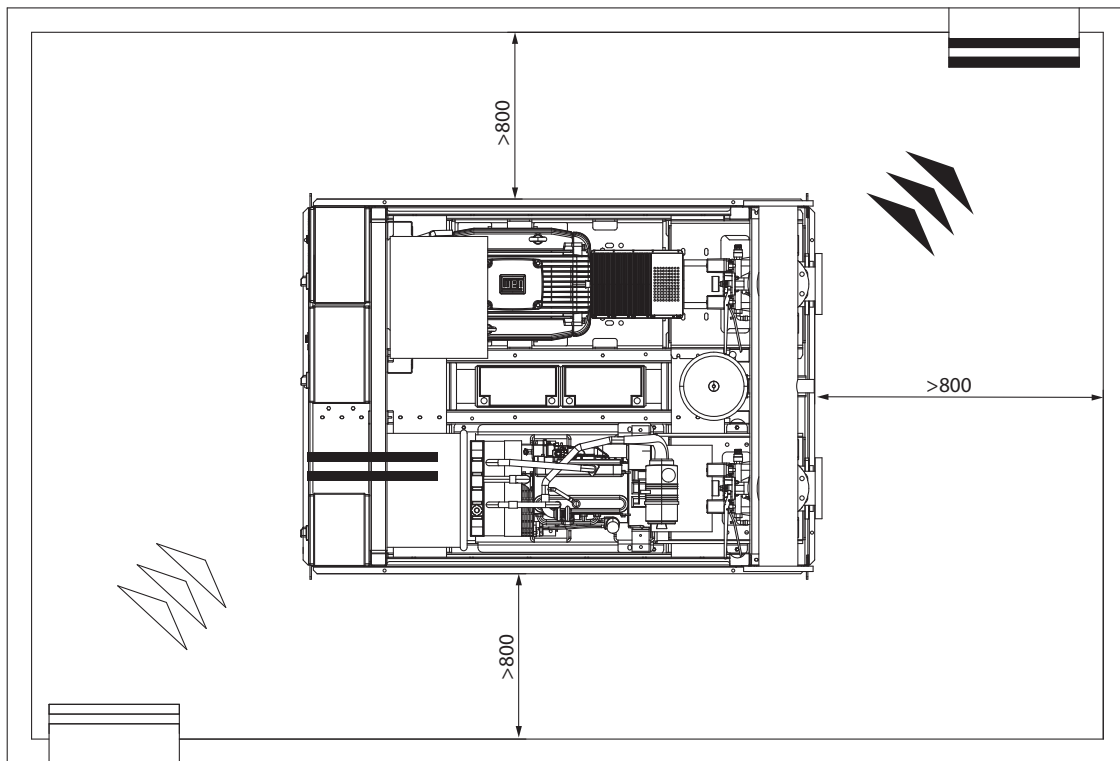

Fig. 10:

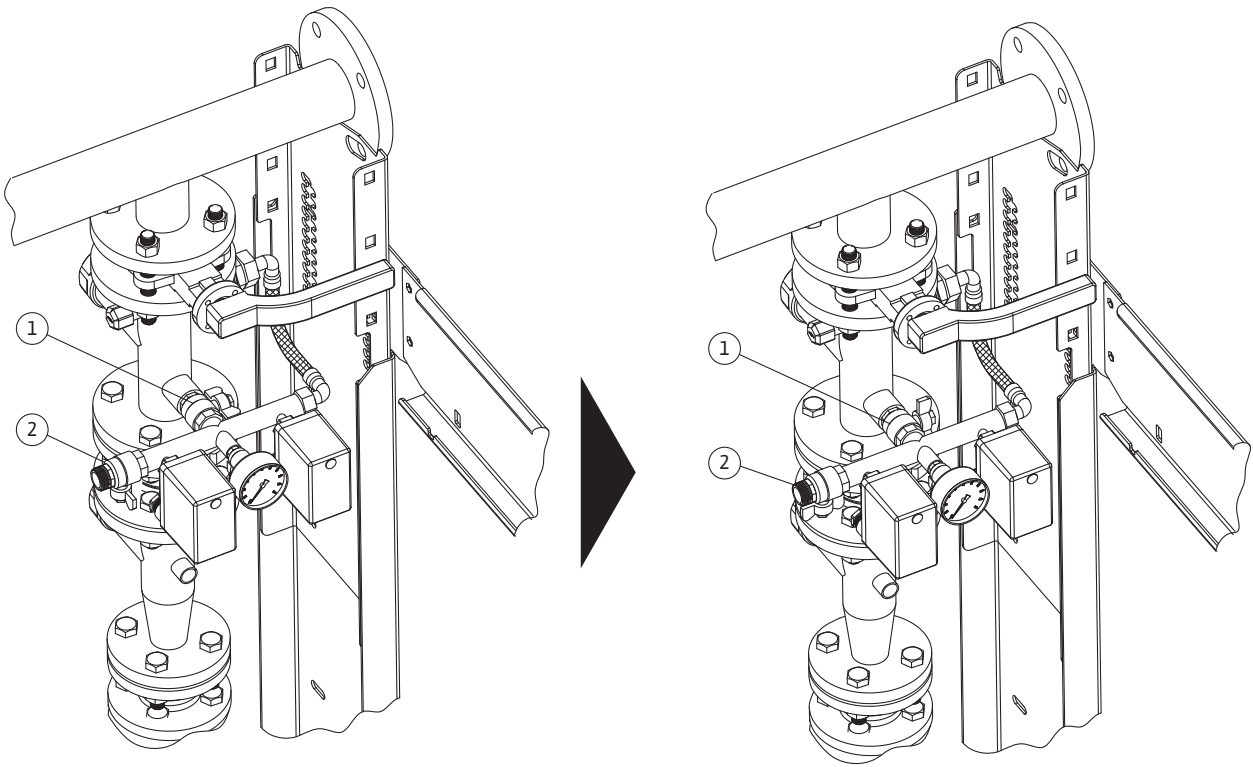
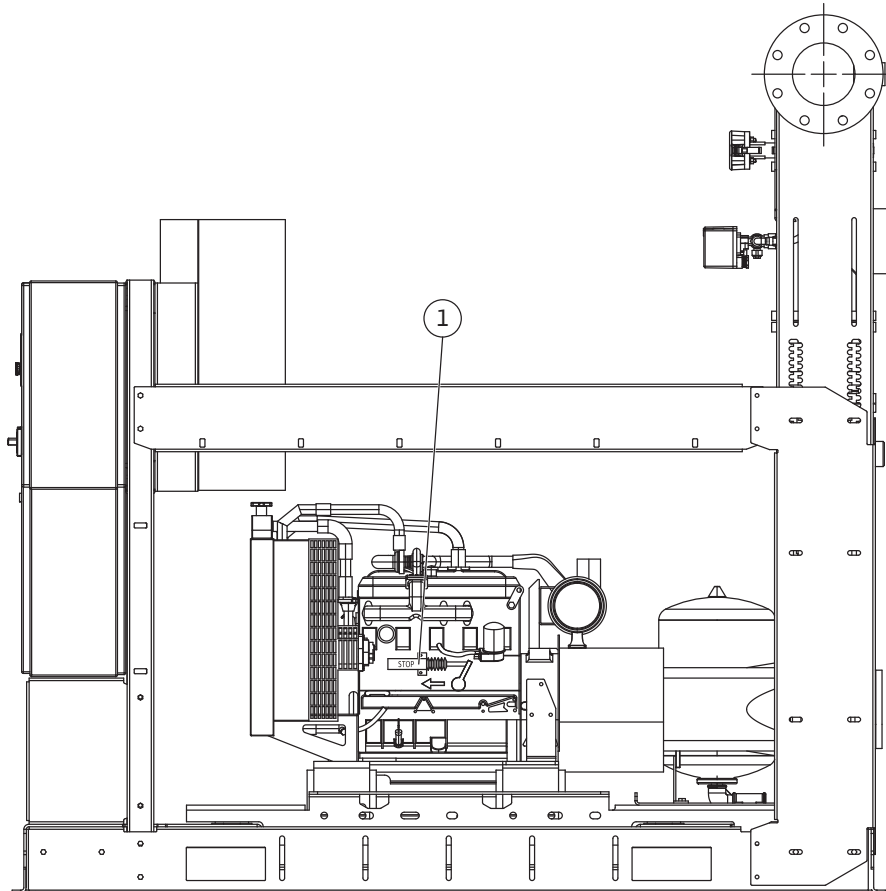

Fig. 11:



Captions

Fig. 1 Transport (example)

Fig. 2a Installation diagram	
A	From water mains
B	Tank 500 L
C	Overflow
D	Drain
E	Standard scope of delivery

Fig. 2b Installation diagram	
1	Jockey pump
2	Non-return valve
3	Test discharge
4	Pressure switch
5	Pressure gauge
6	Diaphragm pressure vessel

Fig. 3 Pressure boosting system	
1	Gate valve
2	Connection for local sprinkler
3	Double pressure switch for the circuit of the main pump
4	Non-return valve
5	Flexible vibration-damping sleeves for diesel pump
6	Connection for recirculation circuit with diaphragm
7	Divergent cone on discharge side main pump
8	Pump/motor coupling with spacer
9	Main pump electric/diesel motor
10	Coupling guard
11	Main pump switchgear
12	Jockey pump switchgear
13	Discharge manifold
14	Connection for setting of flow meter option
15	Fuel tank (for diesel pump)
16	Connection for priming circuit of main pump
17	Main pump
18	Jockey pump
19	Tank for fuel leakages
20	Fuel tank vent valve
21	Fuel level gauge
22	Drain for cleaning of deposit in fuel tank
23	Drain for cleaning of deposit in tank for fuel leakage
24	Fuel filler cap

Fig. 3 Pressure boosting system	
25	Connection for motor return pipe
26	Connection for fuel supply to the motor
27	Level gauge for fuel

Fig. 4 Anchoring to the floor**Fig. 5** Pump test drainage

Fig. 6a Unit with positive head	
Fig. 6b	
C =	Tank capacity

Fig. 7 Unit with suction lift	
A	From water mains
B	Tank 500 L
C	Overflow
D	Drain

Fig. 8 Fuel tank	
1	Fuel level indicator
2	Filling cap
3	Fitting for return pipe from motor
4	Drain for removing deposits in tank
5	On/Off valve for fuel to motor
6	Fitting for fuel supply to motor
7	Tank vent valve (should vent outside room)
8	Electric float connected to motor pump switchgear

Fig. 9a Exhaust air for combustion and cooling diesel engine	
Fig. 9b	
A	Muffler
B	Exhaust thermal protection
C	Condensation drain
D	Expansion joint

Fig. 9a	Variant;
Fig. 9b	Exhaust air for combustion and cooling diesel engine
A	Muffler
B	Exhaust thermal protection
C	Condensation drain
D	Expansion joint

Fig. 10 Automatic running test

Fig. 11 Solenoid valve

1	General information	41
2	Safety.....	41
2.1	Danger symbols used in this operating instruction	41
2.2	Personnel qualifications.....	41
2.3	Danger in the event of non-observance of the safety instructions	42
2.4	Safety consciousness on the job.....	42
2.5	Safety instructions for the operator	42
2.6	Safety instructions for installation and maintenance work	42
2.7	Unauthorised modification and manufacture of spare parts.....	42
2.8	Improper use	42
3	Transport and interim storage	42
3.1	Residual risk during transport and storage	43
4	Intended use	43
5	Product data.....	43
5.1	Type key	43
5.2	Technical data	43
5.3	Scope of delivery	43
5.4	Accessories.....	43
6	Description and function	44
6.1	General description	44
6.2	Description of the product	44
6.2.1	Pressure boosting system.....	44
6.2.2	Switchgear.....	45
6.3	Function of the product	45
7	Installation and electrical connection.....	45
7.1	Installation.....	45
7.2	Safety recommendations.....	46
7.3	Control and environment.....	46
7.4	Electrical connection.....	47
7.4.1	General.....	47
7.4.2	Hydraulic connection	47
7.4.3	Protection of the system	47
7.4.4	Unit with positive suction head	48
7.4.5	Unit with suction lift	48
7.4.6	Exhaust air for combustion and cooling diesel engine	48
8	Commissioning	48
8.1	General preparations and check	48
8.2	Unit below water level	49
8.3	Unit below water level (suction operation).....	49
8.4	Function control	49
8.4.1	Commissioning of the main electric pump	49
8.4.2	Commissioning of the main diesel pump	50
8.4.3	Commissioning of the jockey pump	50
8.4.4	Filling of the installation	50
8.4.5	Automatic running test.....	50
9	Maintenance.....	51
9.1	General maintenance requirements	52
9.2	Test of the automatic start of the pump	52
9.3	Test of the automatic start of the diesel pump	53
9.4	Periodic tests	53
9.5	Residual risks during facility management.....	53
10	Switchgears EC-Fire (Electric, Diesel, Jockey)	54
10.1	Switchgear for electric pump - DOL.....	54
10.2	Switchgear for electric pump - Star/Delta.....	55
10.3	HMI for electric pump.....	56

10.4	Switchgear for electric pump – Remote alarms	57
10.5	Switchgear for electric pump – Functions	57
10.6	Switchgear for diesel pump	58
10.7	HMI for diesel pump (description)	59
10.8	Switchgear for diesel pump – Remote alarms	60
10.9	Switchgear for diesel pump – Functions.....	61
10.10	Switchgear for jockey pump	62
10.11	Switchgear for jockey pump – Remote alarms.....	63
10.12	Switchgear for jockey pump – Functions	63
11	Faults, causes and remedies	63
12	Decommissioning and removal	66
13	Spare parts.....	66

1 General information

About this document

The language of the original operating instructions is English. All other languages of these instructions are translations of the original operating instructions.

These installation and operating instructions are an integral part of the product. They must be kept readily available at the place where the product is installed. Strict adherence to these instructions is a precondition for the proper use and correct operation of the product.

These installation and operating instructions correspond to the relevant version of the product and the underlying safety standards valid at the time of going to print.

EC declaration of conformity:

A copy of the EC declaration of conformity is a component of these operating instructions. If a technical modification is made on the designs named there without our agreement or the declarations made in the installation and operating instructions on product/personnel safety are not observed, this declaration loses its validity.

2 Safety

These operating instructions contain basic information which must be adhered to during installation, operation and maintenance. For this reason, these operating instructions must, without fail, be read by the service technician and the responsible specialist/operator before installation and commissioning.

It is not only the general safety instructions listed under the main point "safety" that must be adhered to but also the special safety instructions with danger symbols included under the following main points.

2.1 Danger symbols used in this operating instruction

Symbols:



General danger symbol



Danger due to electrical voltage



Danger due to suspended loads



Danger due to inflammable materials



Risk of electrification



Risk of poisoning



Danger due to hot surfaces



Danger due to hot products



Risk of cuts



Risk of fall



Risk of irritation



Risk of pollution



Risk of explosion



General ban symbol



No access for unauthorised persons!



Do not touch live parts!



Smoking and



open fire prohibited!



NOTE ...

Signals:

DANGER!

Acutely dangerous situation.

Non-observance results in death or the most serious of injuries.

WARNING!

The user can suffer (serious) injuries.

"WARNING" implies that (serious) injury to persons is probable if this information is disregarded.

CAUTION!

There is a risk of damaging the product/unit.

"CAUTION" implies that damage to the product is likely if this information is disregarded.

NOTE:

Useful information on handling the product. It draws attention to possible problems. Information that appears directly on the product, such as

- Direction of rotation arrow,
- Identifiers for connections,
- Name plate,
- Warning sticker

must be strictly complied with and kept in legible condition.

2.2 Personnel qualifications

The installation, operating, and maintenance personnel must have the appropriate qualifications for this work. Area of responsibility, terms of reference and monitoring of the personnel are to be ensured by the operator. If the personnel are not in possession of the necessary knowledge, they are to be trained and instructed. This can be accomplished if necessary by the manufacturer of the product at the request of the operator.

2.3 Danger in the event of non-observance of the safety instructions

Non-observance of the safety instructions can result in risk of injury to persons and damage to the environment and the product/unit. Non-observance of the safety instructions results in the loss of any claims to damages.

In detail, non-observance can, for example, result in the following risks:

- Danger to persons from electrical, mechanical and bacteriological influences,
- Damage to the environment due to leakage of hazardous materials.
- Property damage
- Failure of important product/unit functions
- Failure of required maintenance and repair procedures

2.4 Safety consciousness on the job

The safety instructions included in this Installation and operating instructions, the existing national regulations for accident prevention together with any internal working, operating and safety regulations of the operator are to be complied with.

2.5 Safety instructions for the operator

This appliance is not intended for use by persons (including children) with reduced physical, sensory or mental capabilities, or lack of experience and knowledge, unless they have been given supervision or instruction concerning use of the appliance by a person responsible for their safety. Children should be supervised to ensure that they do not play with the appliance.

- If hot or cold components on the product/the unit lead to hazards, local measures must be taken to guard them against touching.
- Guards protecting against touching moving components (such as the coupling) must not be removed whilst the product is in operation.
- Leakages (e.g. from the shaft seals) of hazardous fluids (which are explosive, toxic or hot) must be led away so that no danger to persons or to the environment arises. National statutory provisions are to be complied with.
- Highly flammable materials are always to be kept at a safe distance from the product.
- Danger from electrical current must be eliminated. Local directives or general directives [e.g. IEC, VDE etc.] and local power supply companies must be adhered to.
- Danger from unintended start must be taken into account.

2.6 Safety instructions for installation and maintenance work

The operator must ensure that all installation and maintenance work is carried out by authorised and qualified personnel, who are sufficiently informed from their own detailed study of the operating instructions.

Work on the product/unit must only be carried out when at a standstill. It is mandatory that the pro-

cedure described in the installation and operating instructions for shutting down the product/unit be complied with.

Immediately on conclusion of the work, all safety and protective devices must be put back in position and/or recommissioned. Danger from unintended start must be taken into account.

2.7 Unauthorised modification and manufacture of spare parts

Unauthorised modification and manufacture of spare parts will impair the safety of the product/personnel and will make void the manufacturer's declarations regarding safety.

Modifications to the product are only permissible after consultation with the manufacturer. Original spare parts and accessories authorised by the manufacturer ensure safety. The use of other parts will absolve us of liability for consequential events.

2.8 Improper use

The operating safety of the supplied product is only guaranteed for conventional use in accordance with Section 4 of the operating instructions. The limit values must on no account fall under or exceed those specified in the catalogue/data sheet.

3 Transport and interim storage

The pressure boosting system for fire extinguishing purposes is supplied on a pallet. It is protected from moisture and dust by a plastic shrink-wrap.

The equipment must be transported by means of authorised load devices. (See example on Fig. 1) WARNING! Risk of personal injury!

The static stability of the unit must be taken into account. Only qualified personnel is allowed to handle the product by using suitable and authorised equipment.

Lifting straps must be fastened to the ring bolts placed on the base frame.

The manifolds do not fit with the handling of the system and must not be used to fix loads in transit.

CAUTION! Risk of product damage!

Handling by using discharge manifold can cause leakages!

On arrival, inspect the pump immediately for any transport damage. If transport damage is detected, the necessary steps involving the carrier must be taken within the specified period.

CAUTION! Risk of product damages!

If the product shall be installed later on, store it in a dry place. Protect it from impacts and any external influences (moisture, frost, etc. ...).

Handle the product with care.



3.1 Residual risk during transport and storage



WARNING! Risk of cuts!
Sharp edges or any not protected threaded parts entail the risk of getting cut. Take necessary cautions to avoid injuries and use protective equipment (wear protective gloves).



WARNING! Risk of personal injury!
Do not stand or put members under the suspended parts during handling and installation. Use protective clothing to prevent accidents (wear helmet and safety shoes).



WARNING! Risk of impact!
Be careful of prominent parts and parts at head level. Use protective clothing to prevent accidents.



DANGER! Risk of fall!
Prohibit access to wells or tanks, where pumps are installed. Wells must be covered.



WARNING! Risk of irritation!
During handling, avoid spillage of battery acid solution which could cause irritations or material damage. Use special protections to avoid contact.



CAUTION! Risk of environmental pollution!
Avoid dumping of oil from the engine or diesel fuel from the tank. During handling, keep them flat. Use suitable protection and implement the necessary measures to prevent pollution of soil, water, etc.

4 Intended use

The pressure boosting systems for fire extinguishing purposes are designed for professional use. They are used when an increase of pressure or a maintaining under pressure of the fire network is necessary.

The system must be installed in a special room which is protected from frost and rain, fireproof and ventilated enough, with necessary spaces around pumps for movements and regular maintenance. The room must be in accordance with the EN 12845 standards. Airflow for ventilation and for cooling of engines, more specifically diesel engine –if present– has to be sufficient.

5 Product data

5.1 Type key

Example: SiFire Easy 40/200-180-7.5/10.5 EDJ	
SiFire:	Name of the fire fighting system for sprinkler systems according to EN 12845
40/200:	Type of the pump
180:	Impeller diameter of main pump
7.5/10.5:	Rated power of pumps (kW)–electrical motor/diesel motor
EDJ:	Configuration E : 1 electric pump D : 1 diesel pump EJ : 1 electric pump + 1 jockey pump EEJ: 2 electric pumps + 1 jockey pump EDJ: 1 electric pump + 1 diesel pump + 1 jockey pump DJ : 1 diesel pump + 1 jockey pump

5.2 Technical data

Maximum operating pressure:	10 bar (16 bar on request)
Maximum ambient temperature:	5 to +40 °C (10 to 40 °C if diesel pump is installed)
Maximum water temperature:	5 to +40 °C
Supply voltage:	3 x 400 V +/- 10% (1 x 230 V +/- 10%, for diesel pump switchgear)
Frequency:	50 Hz
Maximum relative humidity:	50% with T.max 40 °C (*)
Protection class of switchgear:	IP54
Protection class of pump:	IP55
Insulation class:	F
Efficiency class:	IE2 up to 5.5 kW – IE3 from 7.5 up to 55 kW
Maximum altitude for installation:	1000 m above sea level (*)
Minimum atmospheric pressure:	760 mmHg (*)
Rated current:	refer to the rating plate

(*) Seen the specific graphs and tables in the catalogues and maintenance manuals for the details of class variations for electric and diesel engines with regard to different temperatures, altitudes, atmospheric pressure, fuel temperature and viscosity compared to standard test conditions.

5.3 Scope of delivery

- Pressure boosting system for fire fighting
- Operating instructions for the fire fighting system.
- Operating instructions for the pumps (1 manual per pump type)
- Operating instructions for the switchgear (1 manual per switchgear type)
- Operating instructions and maintenance of diesel motor if present.

5.4 Accessories

- Priming tank(s) complete with electrical float;
- Electric contacts limit for check valve of pumps;
- Flexible vibration–damping sleeves;
- Eccentric suction cone kit with vacuum gauge for suction side of the pumps;
- Butterfly valves;
- Silencer for diesel engine;

- Water/water heat exchanger for diesel engine cooling;
- Flow meter;
- Diesel engine spare parts kit;
- Remote alarm switchgear;

The installer is responsible for the assembly of the equipment supplied and for completion of the system in compliance with the requirements of EN 12845 and others applicable standards for fire fighting systems as well as for integration of our supply with all other necessary components (circulation piping, flow rate metering circuits with meter, priming tank, etc).

See the specific instructions provided in the relevant instruction manuals and/or the indications provided on the items themselves for details of how to assemble, set and adjust the accessories listed above or other particular accessories requested at the order stage and supplied with the standard pumping unit.

The installer is responsible for issuing the final certification "installation built in compliance with EN 12845 standard", as required by the relevant standards, and for issuing the end-user with all the documents foreseen by the applicable standard.

6 Description and function

6.1 General description

There are several variants and models of the fire fighting unit of the SiFire series as indicated in our catalogues, or in versions modified in order to satisfy particular customer requirements (transport/handling difficulties, particular performances, etc), using the main components described below:

- Main norm pump in "back pull out" design, coupled to an electrical motor or diesel engine by a spacer allowing the dismantling of the pump and/or motor without having to work on the other. It also allows the extraction of the rotating part of the pump for maintenance without having to remove the motor and/or the end suction pump housing;
- Vertical multistage jockey pump for correcting small losses and for keeping the system pressure constant;
- Electrical switchgears for the main and jockey pumps (one per pump);
- Piping and discharge manifolds in steel;
- Valves on the pump discharge that can be locked in the open position;
- Non-return valves on the pump discharge;
- Butterfly valves, manometers, pressure switches;
- Connection for flow meter to control the performance of the pumps;
- Double pressure switch for the circuit to start the main pumps and control of the working order of each individual pressure switch;
- Pressure switch for automatic start-up and stop of the jockey pump;
- Support frame(s) for switchgears and manifolds;

- Independent fuel tank for the diesel engine, completed with accessories;
- Two batteries for the start-up of the diesel engine (if present);

The system is assembled on a base frame in accordance with the EN 12845 standard, within the delivery limits, indicated on installation diagram from Fig. 2a-2b.

Each pump is installed on a steel base frame. Diesel pumps are connected to hydraulic elements with intermediary vibration damping joints to avoid the transmission of vibrations from diesel motors but also the possible piping or mechanical structure breaks.

For connection to the public water distribution, rules and existing standards must be respected and possibly completed with rules of water distribution companies. Besides, local particularities have to be taken into account, for example a too high or too variable suction pressure which requests the assembly of a pressure reducing valve.

6.2 Description of the product

6.2.1 Pressure boosting system

see Fig. 3 – Position:

- 1 Gate valve
- 2 Connection for local sprinkler
- 3 Double pressure switch for the circuit of the main pump
- 4 Non-return valve
- 5 Flexible vibration-damping sleeves for diesel pump
- 6 Connection for recirculation circuit with diaphragm
- 7 Divergent cone on discharge side main pump
- 8 Pump/motor coupling with spacer
- 9 Main pump electric/diesel motor
- 10 Coupling guard
- 11 Main pump switchgear
- 12 Jockey pump switchgear
- 13 Discharge manifold
- 14 Connection for setting of flow meter option
- 15 Fuel tank (for diesel pump)
- 16 Connection for priming circuit of main pump
- 17 Main pump
- 18 Jockey pump
- 19 Tank for fuel leakages
- 20 Fuel tank vent valve
- 21 Fuel level gauge
- 22 Drain for cleaning of deposit in fuel tank
- 23 Drain for cleaning of deposit in tank for fuel leakage
- 24 Fuel filler cap
- 25 Connection for motor return pipe
- 26 Connection for fuel supply to the motor
- 27 Level gauge for fuel

∅ Discharge of main pump	∅ Accessories	∅ Manifolds
DN32	DN50	DN65
DN40	DN65	DN65
DN50	DN65	DN80
DN65	DN80	DN100
DN80	DN125	DN125
DN100	DN150	DN150

6.2.2 Switchgear

- Ensure complete automatic operations of each pump and associated functions
- Waterproof, protection class IP 54.

6.3 Function of the product

The operational logic for the fire fighting unit is based on the cascade calibration of the pressure switches for pump starting. It is only possible to stop the main pump manually if the pressure has been replaced in the plant, or by switching off the automatic mode before stopping the pump.

The jockey pump of the pressure boosting system is the first to start and maintains the system full of water and under pressure. It starts when the pressure drops in the system. Start and stop control is set up via the suitably calibrated pressure switch.

When a larger quantity of water is requested due to opening one or more circuits or due to a broken sprinkler, pressure decreases in the system. This causes the start of the main pump.

For systems with more than one pump, if the main electric pump does not start (e.g. due to electricity problems) the drop in pressure will activate the standby pump pressure switch which starts the diesel engine. In some cases, two or more electric pumps could be used.

Once the sprinkler circuit or the gate valve that supply the sprinkler system is closed, the system reaches the maintaining pressure of the installation; it will be necessary to push the "Stop" buttons on the switchgear to stop the main pump and the standby pump. The jockey pump is automatically stopped.

7 Installation and electrical connection



DANGER! Risk of electric shock!

Personnel dedicated to the connection of electrical equipment and motors must be skilled for such work. They shall make the connection according to the wiring diagrams supplied, in accordance with regulations and laws in force. In addition, they must ensure that they have shut down power before performing any operation which provides the possible contact with the electrical parts. Check earth continuity.

7.1 Installation

Install the pressure boosting system in an easily accessible room, ventilated and protected from rain and frost.

Make sure that the unit can pass through the room door.

There must be sufficient space provided for maintenance work. The unit must be easily accessible. The installation place has to be horizontal and flat. It must be robust enough to support the system's weight.

The room must be exclusively dedicated to fire equipment, directly accessible from outside, and have a fire resistance of at least 60 minutes (see standards).

The room must be, in order of preference:

- isolated from the protected building,
- close-by to the protected building,
- inside the protected building.



NOTE:

For rooms with closed walls or inside the building, it is preferable to have a fire resistance superior to 120 minutes. The temperature inside the room cannot be less than 10 °C (4 °C in the presence of electric pumps only) or beyond 25 °C (40 °C in the presence of electric pumps only);

The room must be equipped with openings to atmosphere to ensure adequate ventilation for cooling engines (electric and diesel) and for diesel engine combustion.

The room also shall be equipped with a sprinkler-type protection (EN 12845).

The Sprinkler protection can be directly supplied by the discharge manifold of the pressure boosting system, as required by the EN 12845 standard. Access to the room must be guaranteed and easy for people, even if the installation of fire is on, without light, if there is snow or rain, and in any case that can negatively affect the access. Access to the room must be sufficiently reported and admitted only to authorised, specialised and properly trained personnel.



Avoid access to the system for unauthorised persons!

The pressure boosting system is a fire fighting equipment using AUTOMATIC START and MANUAL STOP ONLY. For this reason, there must be a clearly visible sign in the system room warning of the possibility of an unexpected automatic start due to this logic operation.

The pump unit is NOT equipped with emergency stop. The main pumps can only be stopped manually. (See corresponding part of this manual about the switchgear)

For this reason, before an intervention on pump units, make sure you switch off power supply and avoid any start of pumps.

If possible, pumps must be installed under the charge of water. They are considered as such if at least two thirds of the actual capacity of the suction tank is above the level of the axis of the pump and the minimum useful level of the water in the tank is not more than two meters below the axis of the pump.

If the conditions mentioned above are not respected, the pressure boosting system is considered on suction conditions, which is accepted after installation of special devices, explicitly described by the standard (priming tanks, separated pipes suction, etc).

7.2 Safety recommendations



WARNING! Risk of cuts!

Do not remove the protection on any rotating parts, belts, hot surfaces etc. Never leave tools or disassembled parts of the pressure boosting system on it or around it.



WARNING! Risk of fatal injury!

Do not remove the protection of live parts. Prevent each possibility for operate any element that isolates the installation or subassemblies on which to work.



DANGER! Risk of fatal injury!

Take all precautions to avoid a risk of electrocution. Control earth connection, presence and continuity, and if a device for protection against indirect contact is installed (differential switch). If necessary, use required equipment (insulating gloves, isolating baseplate) when operating on the unit.

Never leave the switchgear or the terminal box of electrical motor powers opened. Check if there is no possibility of contact with live parts. Check if electrical connections and auxiliary power are correctly connected. Check the label data of the electrical switchgear, in particular tension and availability of an adapted power supply.



WARNING! Risk of fire or flash fire!

The charging diesel pump batteries may produce potentially explosive gas; Avoid flames and sparkles.

Never leave flammable liquids or rags dipped in acid around the pressure boosting system or electrical equipment.



DANGER! Risk of fatal injury!

Ensure the correct ventilation of the pump room. Check that the exhaust of the diesel engine is free and the tube allows the removal of exhaust gases outside the room safely, away from doors, windows and vents.



WARNING! Risk of burn!

Check that exhausting pipes are correctly supported, equipped with anti-vibration couplings/flexible vibration-damping sleeves and protected against accidental contacts.



CAUTION! Risk of damage of the installation!

Check if suction and discharge pipes of pumps are correctly supported and equipped with flexible vibration-damping sleeves.



CAUTION! Risk of product damage!

Check that the fluid level of the diesel engine (oil/water) is correct and that plugs of the water and oil circuit are properly fastened. For internal combustion engines with heat exchanger water / water, check that the valve of the cooling circuit is locked in the OPEN position.

Check oil and diesel fuel, then control if there are no fluid losses.



CAUTION! Risk of product damage!

For heating the oil/water of the diesel engine, an immersion or contact resistor supplied with 230 V may be installed.

7.3 Control and environment

- Control electrical pumps or diesel pumps, as mentioned on the instruction manuals for both kind of pumps.
- Provide sufficient space for maintenance of pumps, motors, switchgears and installed accessories.
- Prepare a surface with reinforced concrete for installation of the pressure boosting system. It has to be perfectly flat and horizontal accordingly to the information in the project documentation, complete with bolts which have a diameter adapted to the weight of the unit. (See Fig. 4)
- Make connections to pipes of different circuits, without transmitting mechanical stress, which can damage equipment or pipes;
- Check fluid levels of the diesel pump unit (engine oil, fuel, water for cooling, battery fluid, etc). If necessary, adjust the levels in accordance with instructions mentioned in the operating manual for the diesel motor.

The unit can be attached to the foundation in many ways through special holes provided in the four corners. The chosen method depends on the size, location and installation limitations of acoustic and vibration levels. In order not to transmit tension to the base frame, get the defects of alignment between the anchors and the support surface with metal shims, as shown in figure 4.



CAUTION! Risk of contamination and damage to health!

For units with a diesel pump, waterproof the floor of the system room to avoid contamination of the subsoil because of possible diesel or engine oil losses.

**NOTE:**

It is recommended to equip the pump's switchgear with an alarm system for pump failure, under voltage condition, etc.

7.4 Electrical connection

7.4.1 General



DANGER! Risk of fatal injury!

Electrical connections must be carried out by authorised and skilled personnel in accordance with standards and laws in force. Power supply must be available at any times (EN 12845 10.8.1.1).

- Check the type of power supply and the available voltage and compare them with data of pumps, motors, switchgear and other devices. Before performing an intervention, control the earth connection.
- For connection to power supply networks, use one-piece cables, without joints, exclusively dedicated to the pump unit for the fire department, connected in front of the main power supply switch of buildings.
- Use cables with a suitable diameter whose characteristics and dimensions are in compliance with IEC standards in force and with specifications required by the EN 12845 standard.
- To protect the cables from direct exposure in case of fire, they must pass through pipes buried outside the building or through parts of the building where the fire hazard is negligible. If it is not possible, they must also have an additional direct protection with a 180 minutes fire resistance.
- Make connections are done according to the wiring diagrams supplied with the switchgears.
- The main electrical box must be located in compartment protected against fire and exclusively used for power supply.
- Electrical connections in the main box must be made to ensure continuous power supply to the pump's switchgear even if power is cut to other utilities.
- The fire extinguishing pump supply lines, classified as safety service supply lines CEI 64.8 – 56, must ONLY be protected against short-circuits and direct contacts.
THEY MUST NOT BE PROTECTED AGAINST OVERLOADS.
- For protection, see the requirements of the electricity project (earth connection, equipotential bonding)
- Connect batteries for diesel pumps
- Check the tightening of all electrical connections

7.4.2 Hydraulic connection

Connect the following circuits to pumping tank or to priming tanks, by respecting the requirements imposed by standard:

- Flow rate metering circuit for the pump test. If the return to the tank is not possible, plan draining towards the mains drainage (See Fig. 5)

- Recirculation pipes. The recirculation circuit is used to prevent overheating and damage to pumps that remain in operation when the level of pressure in the system is reached and before they are turned off manually by authorised personnel.
- Sprinkler supply circuit of the fire extinguishing system room;
- Connect main pumps and jockey pump to the fire extinguishing system in accordance with the EN 12845 standard and the installation diagram;
- Connect the jockey pump directly to the water tank by using a suction pipe which is adequately proportioned to avoid priming pump trouble;
- Check the tank of the jockey pump pre-inflation and adjust it according to the pressure value which has to be maintained in the system according to the instructions written on the tank or in its instruction manual;

7.4.3 Protection of the system

- The specific standard for fire extinguishing systems foresees protections against short-circuits with the use of high breaking capacity fuses, which allow the passage of initial current for the start of the electric motor for a period longer than 20 seconds. These fuses are held inside the electric pump's switchgear. No thermal protections for the main fire extinguishing pumps are provided.
- Thermal protection against the overload of the jockey pump is installed inside its switchgear. It must be calibrated at a value slightly higher than the absorbed or nominal current (in) for the motor.
- The standard does not stipulate the protection against lack of water of the pumps. In case of emergency, the pumps must use any available water of the tanks for extinguishing fire.
- In the case of a diesel engine, the switchgear of the diesel engine manages engine operating parameters and possible alarms. For more information concerning diesel engine boxes, see the special instruction manual of the switchgear.

INSTALLATION ADVICE

- According to the type of installation planned for the project, the pressure boosting system can operate correctly if the following aspects are considered:
 - pipes are positioned in such a way that air accumulation avoided;
 - suction pipes between the intake point and the pumping has to be as short as possible. Its diameter must be suitable and equal or exceed the minimum required to maintain the maximum speed as indicated in the EN 12845 standard
 - pipes do not have leakages or air infiltration



CAUTION! Risk of malfunction of the pump! Valves or gate valves must not be directly installed on the pump suction.

- Provide an eccentric cone as indicated in the EN 12845 standard;

7.4.4 Unit with positive suction head

[Fig. 6a – 6b] (As defined in EN 12845, point 10.6.2.2)

- Check the minimum level defined for the storage tanks or the minimum historical level for virtually inexhaustible tanks in order to agree with the conditions for the installation of the unit.
- Check if the diameter of the suction pipes is not less than DN 65, and check if max suction speed does not exceed 1.8 m/s.
- Check if the NPSH available on the suction side of the pump is at least 1 meter higher than the NPSH required for flow rate and at the maximum water temperature.
- Fit a strainer outside the water tank on the suction pipes, having a diameter of a size of at least 1.5 of the nominal pipe diameter and that does not allow the passage of parts with a diameter beyond 5 mm.
- Install a gate valve between the strainer and the water tank.

7.4.5 Unit with suction lift

[Fig. 7] (As defined in EN 12845, point 10.6.2.3)

- Check the minimum level defined for storage tanks, or the minimum historical level for virtually inexhaustible tanks;
- Provide a diameter of the suction pipes equal or larger than DN 80 and ensure that the maximum suction speed does not exceed 1.5 m/s;
- Check if the NPSH available on the suction side of the pump is at least 1 meter higher than the NPSH required for flow rate and at the maximum water temperature;
- Provide independent intake pipes for the pumps equipped at the lowest point of the bottom valve;
- Fit a strainer on the suction pipes, before the bottom valve. This strainer must be set up so that it can be cleaned without having to empty the tank. It must have a diameter of a size of at least 1.5 of the nominal pipe diameter and does not allow the passage of parts with a diameter beyond 5 mm.
- The distance between the rotation axis of the pump and the minimum water level must not exceed 3.2 m.
- Each pump must have automatic priming devices in compliance with the requirements of EN 12845, point 10.6.2.4.

7.4.6 Exhaust air for combustion and cooling diesel engine

(Fig. 8) (Fig. 9a – 9b & variant)

If the system is assembled with a pump driven by a diesel engine, the combustion gases of the engine must be evacuated outside by a pipe supplied with an adequate silencer.

Back pressure cannot exceed recommendations for the type of diesel engine installed. The exhaust pipe must have an adequate size respective to the length of piping. It must be isolated and supplied with sufficient protections against accidental contacts with surfaces at high temperatures.

The exhaust tailpipe must not be close to windows or doors. Besides, exhaust gas must not come back into the pump room.

The exhaust tailpipe must be protected against the weather and must not allow the introduction of rainwater into the exhaust pipe or the return of condensate to the engine.

Hoses have to be as short as possible (perfectly no longer than 5.0 m), with as less curves as possible and a radius less than 2.5 times the pipe diameter. Pipes must be supported and a condensate drain system must be supplied with a material resistant to the acidity of the condensate.

The ventilation system in the pump room with diesel pumps with air cooling or air/water exchanger is crucial. This determines the correct functioning of the fire extinguishing system. The ventilation system must allow dissipation of heat generated during operation of the diesel pump system and ensure a correct air flow to cool the engine.

The room's openings must consider the air flow necessary for the engine, which may vary according to altitude. (See manufacturers' data of diesel engine).

8 Commissioning

For the first commissioning, recommend to contact the closest Wilo after-sales service agent or our after-sales call centre.

The commissioning of the pressure boosting system must be performed by qualified staff.

8.1 General preparations and check

- Before switching on for the first time, check that the wiring has been done correctly, particularly the earth connection;
- To make sure that rigid connections are not exposed to mechanical stress;
- Fill the installation and search for possible faults during visual inspection;
- Open the gate valves on the pump sides and on the discharge pipe;



CAUTION! Risk of product damage!

Never let the system run dry. Dry running destroys the pump's mechanical seal tightness.

- **The jockey pump tank is empty of water; inflate it to a pressure 0.5 bar below the pressure which activates the jockey pump.**
- **Do not exceed the maximum inflation value for the vessel.**



CAUTION! Risk of product damage!

Tighten all the supply terminals before the commissioning of the pressure boosting system!

If it is necessary to conduct tests during installation, make sure the pumps are properly filled with water before switching them on.

Before filling the pump unit with water, check the tightness of the components, which could be

loosened during transport and handling.
Do not let the pressure boosting system in automatic mode before the fire fighting system is completely assembled according to the standard; the commissioning of an incomplete fire extinguishing system will void the warranty.

PROCEDURE FOR COMMISSIONING

- During the pumping system automatic mode setting, the maintenance program procedures and the responsibility of operation in case of accidental starting must be defined.
- For models with diesel engine, check the correct filling of batteries before operation.
- For inspection of batteries, follow the instructions of the manufacturer.
- Keep the batteries away from flames and sparkles. For safety reasons do not lean above the batteries in operating state and during installation or removal.
- Check the correct level of fuel in tanks of diesel engines and, if necessary add some fuel when the engines are cold.
- Do not spill fuel on motors, on rubber or plastic materials of the system.
- Do not add fuel when the engines are warm.
- Before turning on the main pumps, check the correct motor-pump alignment. Respect the procedures described in the specific manual delivered with the pumps. The motor-pump alignment operations must be performed by skilled persons.
- If the unit is provided with the pumps placed on a separate base frame, each base frame must be fixed to the ground paying special attention to the alignment of the discharge manifolds.
- The installation must be performed by qualified technicians.

8.2 Unit below water level

For the commissioning of a system installed under water level take the following measures:

- Check if the air ventilation valve of each pump is open;
- Close the valves on the discharge pumps;
- Slowly open the valves on the discharge side and check if water is coming out from the air ventilation circuits of each pump;
- Briefly start the pumps by using the manual mode;
- Make sure there is no air in the circuits and the pumps;
- Repeat the operation until it is sure that all air is eliminated from the pipe;
- Close the ventilation plug of the jockey pump;
- Completely open the valves on the suction and the discharge side;
- Make sure there are no problems of water flow (presence of dirt, solids, etc).

8.3 Unit below water level (suction operation)

For the commissioning of a system installed beyond water level, take the following measures:

- Check if the ventilation valve of each pump is open;

- Close the valves on the discharge pumps;
- Fill the main pumps through circuits from priming tanks;
- Fill the jockey pump through the filler cap by following the instructions given in the instruction manual.
- Briefly start pumps by using the manual mode;
- Make sure there is no air in the circuits and the pumps;
- Repeat the operation until it is sure that all air is eliminated from the pipe;
- Completely open the valves on the suction and the discharge side.
- Make sure there are no problems of water flow (presence of dirt, solids, etc).

8.4 Function control

8.4.1 Commissioning of the main electric pump

- Make sure that any hydraulic, mechanical and electrical connections indicated in this manual are done correctly;
- Make sure the valves at the suction and the discharge side of the pump are open;
- Make sure the pump is primed and filled with water;
- Make sure that the power supply is in accordance with the data indicated on the rating plate and that all three phases are connected correctly. Follow the commissioning instructions indicated in the chapter of the electric pump switchgear.



CAUTION! Risk of product damage!

In order to avoid overheating which can damage the main pumps, always check that the water flow through the recirculation circuit is fitting with requirements of the instructions in the technical manual of the pump. If there is trouble regarding the recirculation circuit or if the minimum level necessary for testing the start and the running of the pump is not guaranteed, open other circuits (for example the flow meter, the valve for testing the tightness of the gate valve, the drain valve, etc.)



CAUTION! Risk of product damage!

Make sure that none of the following situations is present. Otherwise immediately stop the pump and remove malfunctioning causes before starting it again (also refer to the chapter faults, causes and remedies):

- **Rotating parts are in contact with fixed parts,**
- **Unusual noises and vibrations,**
- **Loosened bolts,**
- **High temperature on the motor housing,**
- **Differences in current at each phase,**
- **Leakages on the mechanical seal,**
- **Vibrations, noise and excess temperatures could occur due to misalignment of motor/pump coupling.**

8.4.2 Commissioning of the main diesel pump

- Make sure that any hydraulic, mechanical and electrical connections indicated in this manual are done correctly;
- Make sure that the valves on the suction and the discharge side of the pump are open.
- Make sure the pump is primed and completely filled with water and that air is drained by using the tap on the pump housing.
- Check if the supply voltage is in accordance with the data indicated on the rating plate and if it is present.
- Make sure the fuel is compatible with engine functioning, that the fuel tank is completely filled with fuel (the fuel level inside the tank can be seen via the pipe gauge near to the tank).
- Make sure that connections to the pipes are done correctly without any connection between the tank and the engine
- Make sure the electric float cable of the tank is correctly connected to the electrical switchgear of the diesel pump.
- Check the oil and coolant level of the engine.
- If engines are cooled by water from a cooler or heat exchanger, check the specific procedures specified in the instruction manual of the engine.
- In order to fill-up fluids use oil and coolant advised by indications given in the instruction manuals of diesel engines in annex to this instruction manual. Follow the commissioning procedures indicated in the chapter of the diesel pump switchgear.



CAUTION! Risk of product damage!
In order to avoid overheating which can damage the main pumps, always check that the water flow through the recirculation circuit is fitting with requirements of pump's technical data sheet. If there are problems in the recirculation circuit or if the minimum flow level used to test the start and the running of the pumps is not guaranteed, open other circuits (for example the flow meter, the valve for testing the tightness of the gate valve, the drain valve, etc).



WARNING!
THE ACCELERATOR ENGINE LEVER IS LOCKED. THEREFORE THE ENGINE ALWAYS STARTS AT MAXIMUM SPEED.
Allow the pump to run for 20 minutes to check if the motor speed is compatible with the indication on the unit's rating plate.



CAUTION! Risk of product damage!
Make sure that none of the following situations is present. Otherwise immediately stop the pump and remove malfunctioning causes before starting it again (also refer to the chapter faults, causes and remedies):

- Rotating parts are in contact with fixed parts,
- Unusual noises and vibrations,
- Loosen bolts,
- High temperature on the motor housing,
- Exhaust gas in the pump room

- Leak on the mechanical seal
- Vibrations, noise and excess temperatures could occur due to misalignment of motor/pump coupling.

8.4.3 Commissioning of the jockey pump Manual Start

Follow the commissioning instructions indicated in the chapter of the jockey pump switchgear.

If the direction of rotation is not correct, turn off the electrical supply of the box and swap two of the three phases in the switchgear supply line. Do not invert with the yellow-green earth connection wire.



CAUTION! Risk of malfunction!
Make adjustments for the jockey pump which maintains the pressure on the installation, for example insert a diaphragm valve to ensure that even if only one sprinkler is open, the jockey pump does not compensate pressure loss. For adjustments of jockey pumps, see the curves of different pump types indicated in the catalogue.

If there is trouble regarding the start of the pump refer to the chapter faults, causes and remedies of the jockey pump box and the pump's instruction manuals.

8.4.4 Filling of the installation

If the unit is not filled, use the jockey pump after checking that the procedures described in the previous chapter were done correctly. In that phase, open one or more drain pipes in the sprinkler circuit to expel air from the system. Start the jockey pump. The system is slowly filling, expelling air out of the system. Once the water starts to flow from the drain pipes, close them and wait until the predetermined pressure is reached and the jockey pump stops. If the pump does not stop, check if there are any leaks and check the calibration of the pressure switch again which controls the pump. Once the unit has reached the set pressure, which must be higher than the automatic main pump start-up pressure, wait until the pressure remains stable before switching the system to automatic mode.

8.4.5 Automatic running test Main electric pump

Before testing, make sure that the return circuit in the tank is closed and the main circuit pressure is sufficient to avoid accidental starting of the pump. Start the unit automatically by using one pressure switch at a time to check the correct operation of both switches. Close the valve (pos. 2 Fig. 10) and open the valve (pos. 1 of Fig. 10) to complete and restore the circuit pressure. Then follow pump's switchgear instructions to verify the correct functioning of automatism.



CAUTION! Risk of product damage!
In order to avoid overheating which can damage the main pumps, always check that the water flow through the recirculation circuit is fitting with requirements of the pump's technical data sheet. If there are problems in the recirculation circuit or if the minimum flow level used to test the start and the running of the pumps is not guaranteed, open other circuits (for example the flow meter, the valve for testing the tightness of the gate valve, the drain valve, etc).



CAUTION! Risk of malfunction!
Before leaving the installation and/or after a manual stop, remember to switch the system to automatic mode (refer to the chapter about the switchgear).

OTHERWISE THE FIRE EXTINGUISHING SYSTEM IS NOT ACTIVATED.



CAUTION! Risk of malfunction!
If the pressure in the system has not recovered to the starting level of the main pump switches, refer to the chapter about the switchgear to start the pump manually.

Test of the automatic start with float switch (electric pumps with suction)

- Empty the priming tank (or simulate the effect) to start the electric pump through the float signal.
- Then follow pump's switchgear instructions to check the correct functioning of automatism.

Pump with diesel engine

Before testing, make sure that the return circuit in the tank is closed and the main circuit pressure is sufficient to avoid accidental starting of the pump.

Then follow the pump's switchgear instructions to activate the automatic mode only for the diesel pump.

Automatically start the unit by using one pressure switch at a time to check the correct operation of both switches. Close the valve (pos. 1 of Fig. 10) and open the drain valve (pos. 2 of Fig. 10) to start the pump.

Then follow pump's switchgear instructions to verify the correct functioning of diesel pump automatism.

Close the valve (pos. 2 of Fig. 10) and open the valve (pos. 1 of Fig. 10) to complete the test and restore the circuit pressure.



CAUTION! Risk of product damage!
In order to avoid overheating which can damage the main pumps, always check that the water flow through the recirculation circuit is fitting with requirements of the pump's technical data sheet. If there are problems in the recirculation circuit or if the minimum flow level used to test the start and the running of the pumps is not guaranteed, open other circuits (for example the

flow meter, the valve for testing the tightness of the gate valve, the drain valve, etc.).

Automatic start test with float switch (diesel pump with suction)

Empty the priming tank (or simulate the effect) to start the electric pump through the float signal. Then follow pump's switchgear instructions to verify the correct functioning of automatism.



CAUTION! Risk of malfunction!
If the pressure in the system has not recovered to the starting level of the main pump switches, refer to the switchgear manual to start the pump manually.

9 Maintenance

The fire extinguishing system is a safety equipment that protects objects and people, therefore possible modifications and repairs that affect its efficiency must be made so as to minimise the 'out of order' state.

Isolate pumps one at a time by the selector switches of the switchgear and the stop valves provided for this purpose.



Prohibit access to the pump room to unauthorised persons.



WARNING! Risk of personal injury!
People must always wear personal protective devices. Maintenance must be performed **ONLY** by qualified personnel. In case of lack of instructions, always contact the supplier or expert staff.

Never work alone when the presence of more than one person is required.



Do not remove the protection on any rotating parts, belts, hot surfaces etc. Never leave tools or disassembled parts of the unit on it or around it.



Do not remove the protection of live parts; prevent every possibility for operate any element that isolates the installation or subassemblies to be maintained.



CAUTION! Risk of product damage!
The pressure boosting system is **NOT** equipped with an emergency stop. The main pumps can only be stopped manually by switching off the switchgear.

FOR THIS REASON BEFORE MAKING AN INTERVENTION ON PUMPS, BE SURE TO BE IN POSSESSION OF THE OPERATION KEY (IF EXISTING) OF THE AUTOMATIC/MANUAL SWITCHES.

Open the general isolating switch on the switchgear of the respective pump.

**DANGER! Risk of fatal injury!**

In the case of work with an open switchgear door even after opening the main isolating switch, input terminals from the supply line and those of remote transmission of alarms could still be powered.

**DANGER! Risk of fatal injury!**

For an intervention on the diesel engine, it is advisable to disconnect the positive terminal of the battery to prevent undesired start-ups.

**DANGER! Risk of fatal injury!**

Before changing the engine oil, make sure the temperature is below 60 °C. For water-cooled engines, remove the cap of the cooler or the heat exchanger very slowly. The cooling systems are normally under pressure and violent hot liquid leaks could occur. Check the correct level of engine fluids (oil/water) and the correct tightening of the water circuit and the circuit's oil closure plugs.

NEVER ADD COOLANT TO AN OVERHEATING ENGINE. LET IT COOL DOWN FIRST.

For diesel engines with a heat exchanger with water /water, check that the valves of the cooling circuit are locked in open position. Check diesel and oil hoses and see if there is no fluid leakage.

**DANGER! Risk of fatal injury!**

For oil / diesel engine water heating, immersion or contact supplied with 230 V resistance can be installed.

**WARNING! Risk of fire and personal injury!**

Connecting or disconnecting the battery can generate sparks.

Never connect or disconnect the battery cables when the motor is running.

**WARNING! Risk of burn!**

Hot diesel engine and exhaust pipe surfaces.

**DANGER! Risk of explosion!**

While charging the diesel pump batteries, potentially explosive gas could be formed; avoid flames and sparks.

Never leave flammable liquids or rags soaked with these liquids around the pump units or electrical devices.



DO NOT SMOKE OR USE FLAMES DURING THE CHANGE OF ENGINE OIL OR FUEL PROVISION.

Units installed in accordance with these instructions will operate normally with a minimum maintenance intervention. Inspections and periodic controls are planned and specified by the EN 12845 standard in order to keep the fire extinguishing system and the pressure boosting systems efficient. Refer to the weekly, monthly, quarterly, semiannual, annual, triennial and 10-years program of inspections and checks, prescribed by the EN 12845 standard.

Maintenance must be performed by qualified personnel.

9.1 General maintenance requirements

- General inspection of the unit (including water and power supplies) to check the apparent conditions of all components;
- General cleaning;
- Tightness control of non-return valves;
- Check the operating configuration of the switchgear;
- Check the correct operation of alarm pilot lights on the switchgear;
- Check the correct operation of the minimum tank/well level alarm;
- Check the electrical connections to see if there are any signs of insulation damages, burning, loosening of terminals;
- Check the electric motor's insulation resistance. When it is cold, an engine without insulation damages must have a resistance of more than 1000 Mega ohm;
- Check the pre-inflation of membrane tanks;
- See also specific procedures indicated in the particular instructions manuals for the various components of the pressure boosting system;
- Check if minimum service equipment supply is available in stock which is required by the EN 12845 standard for the quick restoration of the fully working order of the system in case of failure.
- Check the correct functioning of the minimum fuel level alarm;
- Check the correct functioning of the engine oil heater resistor;
- Check the battery charge level and the efficiency of the battery charger;
- Check the correct functioning of the stop solenoid valve (Fig. 11);
- Check the pump cooling oil level and viscosity;
- Check the priming circuit (especially for unit above the level of water charge).
During all inspections, the following points have to be checked:
 - a) All different pressures of the manometer for water and air of the buildings, pressures for main pipes and pressure tanks;
 - b) All water levels in storage tanks, rivers, canals, lakes (including pump priming tanks and under pressure tanks);
 - c) The correct position of all the main gate valves.

9.2 Test of the automatic start of the pump

Tests on automatic pumps must include the following:

- a) Control engine oil and fuel level;
- b) Reduce the water pressure on the starting device, simulating an automatic start request this way (see chapter 8);
- c) When the pump starts, the starting pressure must be checked and recorded;
- d) Check the oil pressure of the diesel pump and the cooling circuit water flow;



CAUTION! Risk of malfunction of the pump!
Always fill-up fuel and other fluids after performing the tests.

9.3 Test of the automatic start of the diesel pump

After testing the start, diesel engines must be tested as follows:

- a) Let the motor run for 20 min or for the time recommended by the supplier. Then stop the engine and immediately restart it by using the test button 'manual start';
- b) Control the water level in the primary cooling circuit.

During the test, you must check the oil pressure, the engine temperature and the coolant flow. Then control the oil hoses and make a general check to detect any possible fuel, coolant or exhaust smoke leakage.

9.4 Periodic tests

MONTHLY INSPECTIONS

Control level and density of the electrolyte of all lead storage battery cells (including diesel engine starting batteries and batteries used for the switchgear's power supply). If the density is low, check the battery charger and if it is correctly working, replace the battery in the case of failure.

QUARTERLY INSPECTIONS

To be performed every 13 weeks at the latest. An inspection report must be recorded, signed and handed over to the end-user.. This must include details of each procedure carried out or planned, details of external factors, such as weather conditions, which could have influenced the results.

Check the pipes and supports to check the possible corrosion points and protect them where it is necessary.

Check the pipes for correct earth connection. Sprinkler pipes cannot be used for electrical earth connection. Remove all these connections and implement an alternative solution.

Check each water supply on each control station of the system. The pump(s) should start automatically, the pressure values and measured flow cannot be less than that reported values on the project. Each change must be recorded.

Check all valves that supply sprinklers with water to ensure that they are working. Then return them to their normal running position. Realise the same operation for all the water supply valves, the control and alarm valves and all local or auxiliary valves.

Check and control the amount and packaging of spare parts that are in stock.

SEMI-ANNUAL INSPECTIONS

To be performed every 6 months.

Check the alarm system and messages of the remote alarm system to the central supervision.

YEARLY INSPECTIONS

To be performed every 12 months at the latest. Test the efficiency of each pump when fully loaded (with the connection between the test pipes to the pump discharge) to control if values of pressure /flow correspond with those indicated on the pump's rating plate.

Consider any pressure losses in the supply pipes and in the valves between the water source and each control station.

Test a diesel engine start failure, then check that an alarm in accordance with standards is working. After this control, immediately restart the diesel engine by using the manual starting procedures. Check if the float valves in the storage tanks are working correctly.

Check the strainers on the pump suction and deposit tank of filtration accessories. Clean them if necessary.

3-YEAR INSPECTIONS

To be performed every 3 years.

After draining all tanks, check the outside and inside for corrosion. If necessary, all tanks must be painted or, protection against corrosion must be applied again.

Examine all the water supply valves, alarm and control valves. If necessary, replace them or maintain them.

10-YEAR INSPECTIONS

To be performed every 10 years

The inside of all water supplies should be cleaned and examined. Tightness must be checked.

Concerning the review process or replacement of damaged parts of the entire system, which no longer perfectly work, contact the Wilo service or a specialised centre.

Refer to the detailed maintenance operations indicated in the manual delivered with the unit. Always replace the equipment with an original spare part or a certified spare part with identical characteristics.

Wilo excludes any liability for damage caused by intervention of unskilled personnel or by replacing original spare parts by other parts with different characteristics.

9.5 Residual risks during facility management



WARNING! Risk of cuts!

Sharp edges or any not protected threaded parts entail the risk of getting cut. Take necessary cautions to avoid injuries and use protective equipment (wear specific gloves).



WARNING! Risk of impact injury!

Be careful of prominent parts and height. Wear special protection clothing.



DANGER! Risk of fatal injury!

Do not exceed the nominal pressure limits for the vessel of the jockey pump in order to avoid possible explosions.



DANGER! Risk of electric shock!
 The people dedicated to the connection of electrical equipment and motors must have obtained a certificate for this kind of work and shall make the connection in accordance with regulations and laws in force. They should ensure that they have shut down power before performing any work which provides the possible contact with electrical parts. Check earth continuity. Avoid contact with water.



WARNING! Risk of fall
 Take precautions to protect access to tanks or wells. Wells must be covered.



WARNING! Risk of burn!
 Take precautions to avoid contact with hot engine parts. Use protections for parts of the engine and the exhaust pipe. Fill-up fuel in the tank when the diesel engine is cold. During refilling, do not drop fuel on hot parts of diesel engine. Wear special gloves.



WARNING! Risk of irritation!
 During refilling and level controls, avoid spillage of battery acid solution which can cause irritations or material damage. Do not approach the refilling area with eyes. Use special protections to avoid contact.



DANGER! Risk of fatal injury!
 Avoid turning on the diesel pumps if exhaust smoke pipes were not connected towards outside the room.



CAUTION! Risk of environmental pollution!
 Avoid dumping oil from the engine or diesel fuel during inspection and refilling. Use appropriate protection and take necessary precautions.



DANGER! Risk of fatal injury!
 Risk of unintended start. Avoid maintenance work on the pump unit if the automatic mode is switched on.

10 Switchgears EC-Fire (Electric, Diesel, Jockey)

10.1 Switchgear for electric pump – DOL Fig. 12a

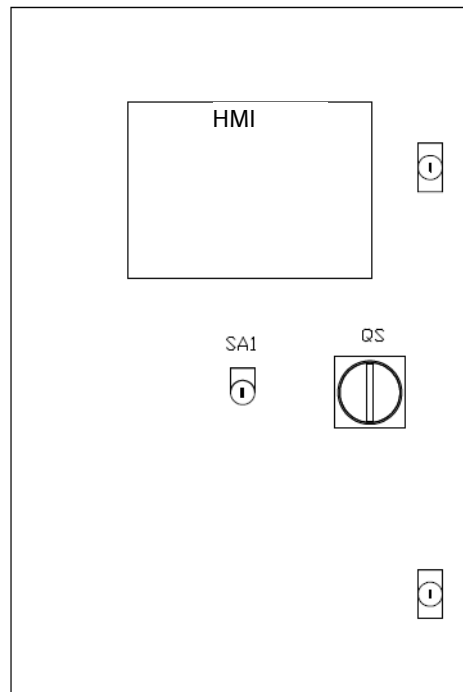
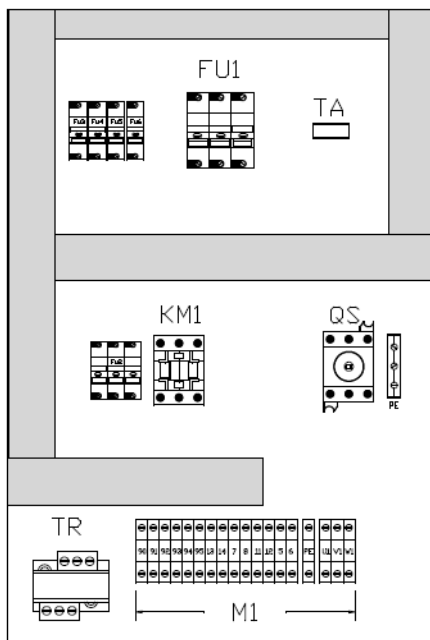

Description

HMI	Human Machine Interface to manage the FF electric pump
QS	Door locking switch – provide to switch on and off the mains to the switchgear
SA1	Automatic mode switch
FU1	Mains fuses
TA	Ammeteric transformer
KM1	Contactor
TR	Power transformer
M 1	Terminals

10.2 Switchgear for electric pump – Star/Delta

Fig. 12b

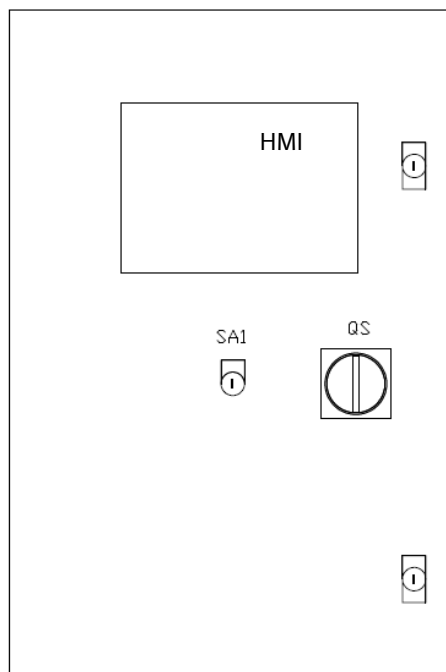
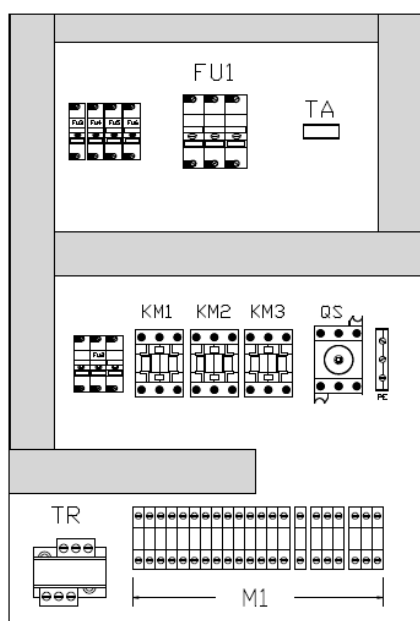

Description

HMI	Human Machine Interface to manage the FF electric pump
QS	Door locking switch – for switching on and off the mains to the switchgear
SA1	Automatic mode switch
FU1	Mains fuses
TA	Current transformer
KM1/KM2/KM3	Contactors
TR	Power transformer
M 1	Terminals

10.3 HMI for electric pump

Fig. 13

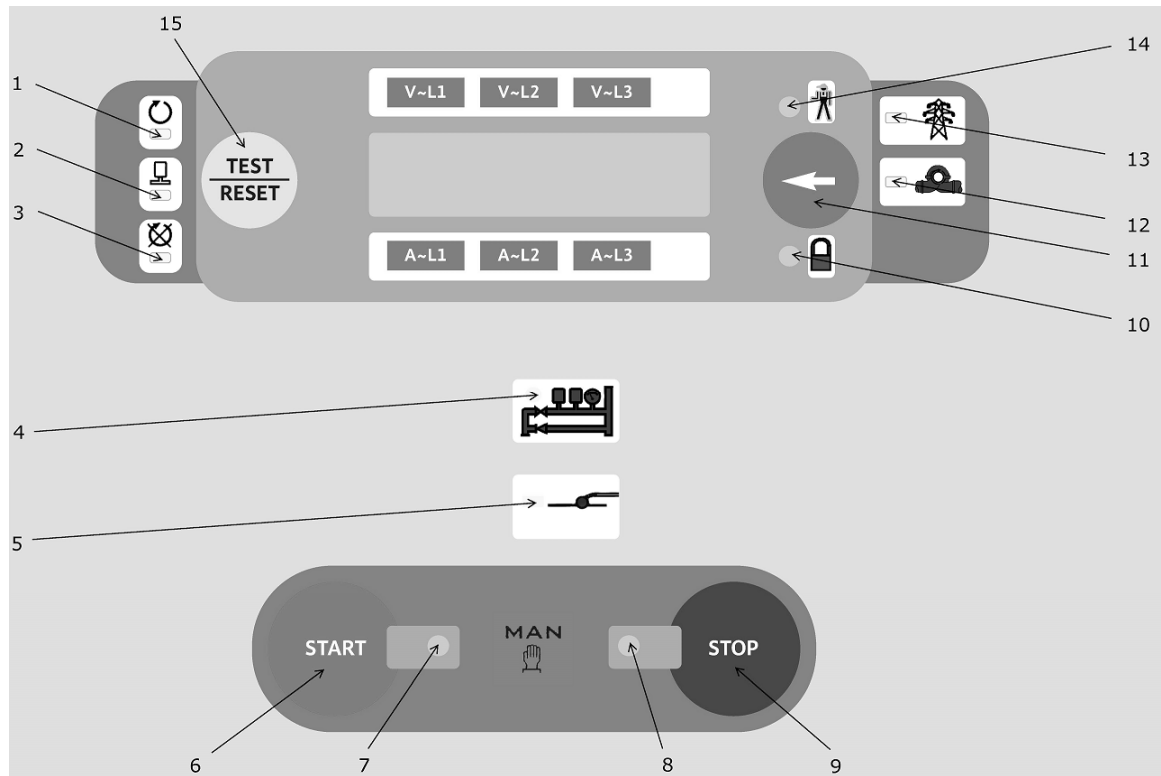

Description

1	Motor running, checked by ammeter reading
2	Electric pump running detected by Ampere of the motor
3	Start failure
4	Start-up call received from pressure switches
5	Start-up call received from float in priming tank
6	Manual start button
7	Electric pump started via button
8	Electric pump stopped via button
9	Manual stop button
10	Automatic mode switched off
11	Push to view tools
12	Pump start-up call
13	Power on
14	Cumulative alarms
15	LED Test - reset

INSTRUMENTS

Three mains voltmeter	Push button 11 on Fig. 13 to see the values For three-phase voltage up to 570 V
Amperemeter	To check Ampere on the phase of electric motor
Wattmeter	
Varmeter	
Voltammeter	Displays apparent power up to 750 kVA
Cosphimeter	
Total and partial hour meter	Displays hours and minutes

10.4 Switchgear for electric pump – Remote alarms

Remote alarm	Description	Terminals on switchgear	Symbol on HMI Fig. 13
Electric power supply not available	It is detected when one of the following failures occurs: <ul style="list-style-type: none"> • Voltage value failure • Phase sequence not correct • Blown switchboard fuses • Automatic mode switched off • Alarms 	90-91	10/13/14
Electric pump start request	It is detected at the opening of the pump pressure switches or at the closing of the pump priming tank float contact.	90-95	12
Electric pump in operation		90-92	2
Electric pump start failure		90-94	3/14

10.5 Switchgear for electric pump – Functions

AUTOMATIC MODE SWITCHING	To switch on/off the automatic mode use the selector SA1 on Fig. 12a. It is only possible to remove the key from the switchgear, if the automatic mode is switched on. If the automatic mode is switched off, a flashing warning light 10 on Fig. 13 appears.
AUTOMATIC START	It takes place when the CALL pressure switch contacts are open, which is indicated by a permanent light 4 on Fig. 13. When the pressure switches contact will be closed (pressure is replaced) the indicator 4 on Fig. 13 starts to flash. From this moment you can stop the motor only manually by pushing the button 9 on Fig. 13. The automatic start also takes place also when the pump's priming float contact is closed, which is indicated by a permanent light 5 on Fig. 13. When the contact opens, the indicator starts flashing. From this moment you can stop the motor only manually by pushing the button 9 on Fig. 13.
MANUAL START	Push button 6 on Fig. 13, a permanent light 7 on Fig. 13 appears.
MOTOR IN OPERATION	Indicated by a permanent light 1 on Fig. 13. It is detected when the motor current is higher than the threshold set for the entire duration of the intervention delay.
ELECTRIC PUMP IN OPERATION	Indicated by a permanent light 2 on Fig. 13. When the motor starts, this is detected by the value of power (kW) and by closing of the pump's pressurized-pressure switch (when it is installed on the pump as demanded).
STOP	It is only possible to switch off the motor manually by pushing the button 9 on Fig. 13. Warning: It is not possible to stop the motor when the call from the pressure switches is present and automatic mode is switched on. In this case it is possible to stop the motor only by switching off the automatic mode and pushing the button 9 on Fig. 13.
ALARMS	The alarms are indicated on the display by the relevant LED and by a cumulative flashing LED 14 on Fig. 13.
RESTORING	To RESET it is possible to push the button 15 on Fig. 13. This way, the protections are activated and the startup cycle controlled by the priming tank float is released.
LIGHTS TEST	Keep the button 11 on Fig. 13 pushed to check all the light.

10.6 Switchgear for diesel pump

Fig. 14

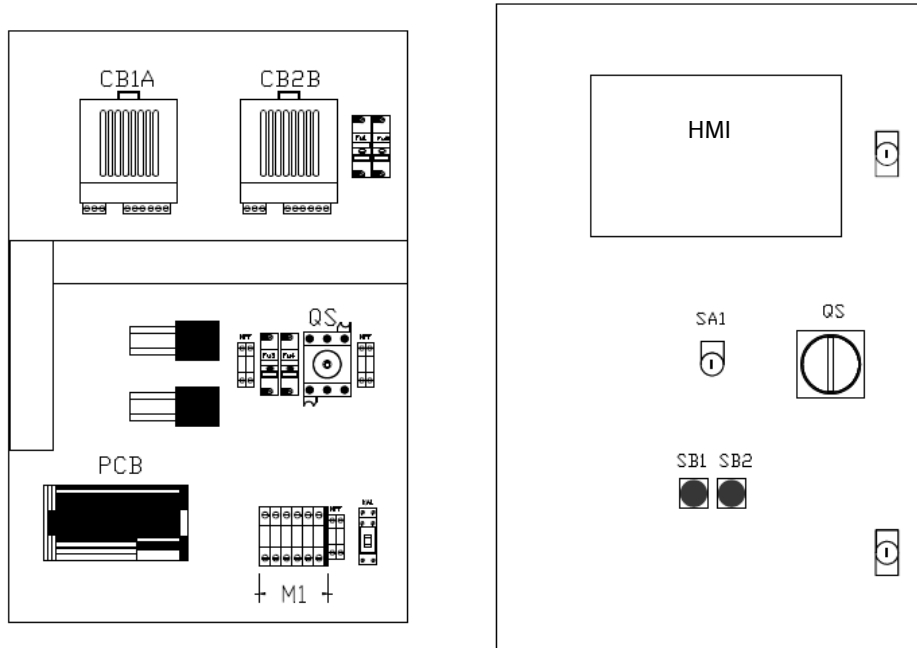

Description

HMI	Human Machine Interface to manage the FF electric pump
QS	Door locking switch – provide to switch on and off the mains to the switchgear
SA1	Automatic mode switch
FU	Fuses
KA1	Auxiliary relay
CB1A	Battery charger - Battery 1
CB2B	Battery charger - Battery 2
SB1	Emergency manual start button - Battery 1
SB2	Emergency manual start button - Battery 2
M 1	Terminals

10.7 HMI for diesel pump (description)

Fig. 15

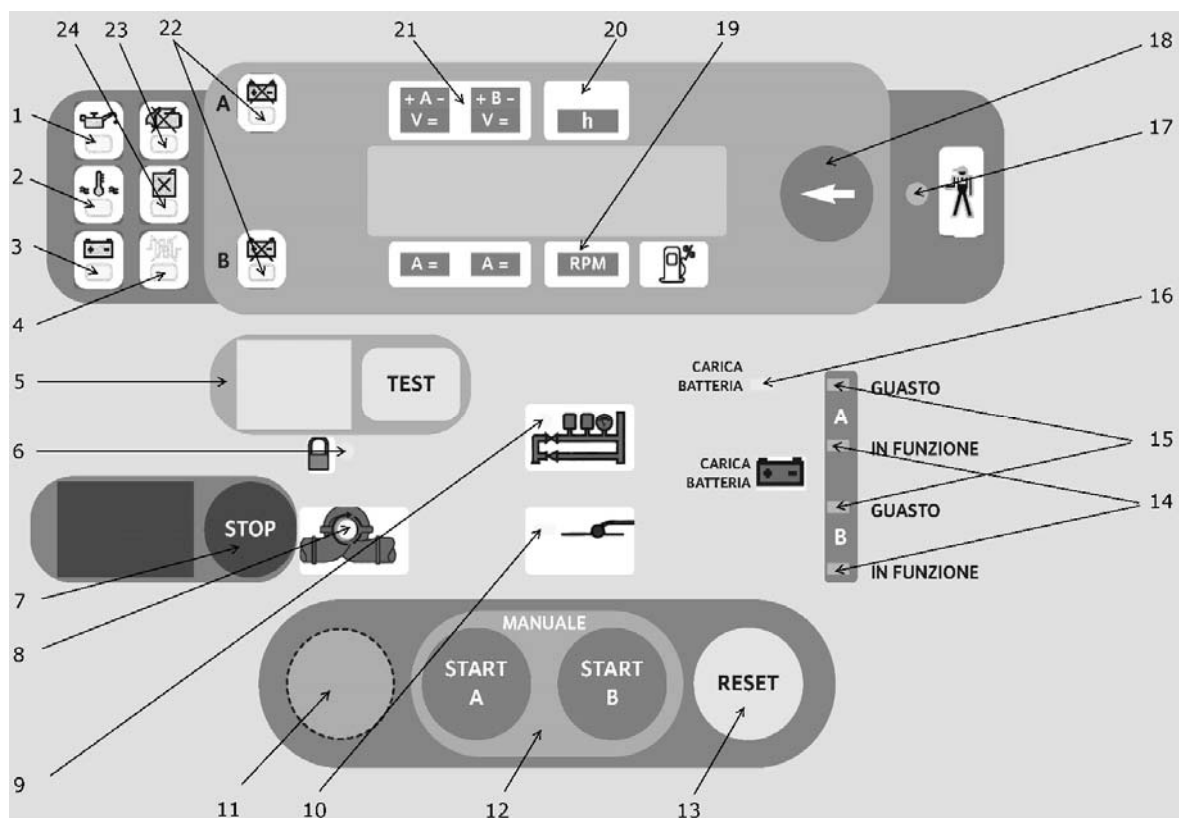

Description

1	Low oil pressure
2	Overheating
3	Broken belt alarm - no battery charging
4	Oil/water heater failure
5	Manual start-up test light and button
6	Automatic mode switched off
7	Motor pump stop button
8	Diesel pump running
9	Start-up call from pressure switches
10	Start-up call from float in priming tank
11	On-site commissioning test
12	Manual motor pump start with batteries A and B (always active)
13	Reset alarms
14	Battery charger working
15	Anomalies on battery charging detected by battery charger
16	No mains power to battery charger - alarm
17	Cumulative alarms
18	Push briefly to view tools - keep it pushed through for LED test
19	Rev counter
20	Timer
21	Battery chargers A and B voltmeters
22	Battery A or B alarm
23	Start failure alarm
24	Fuel level alarm

Fig. 16

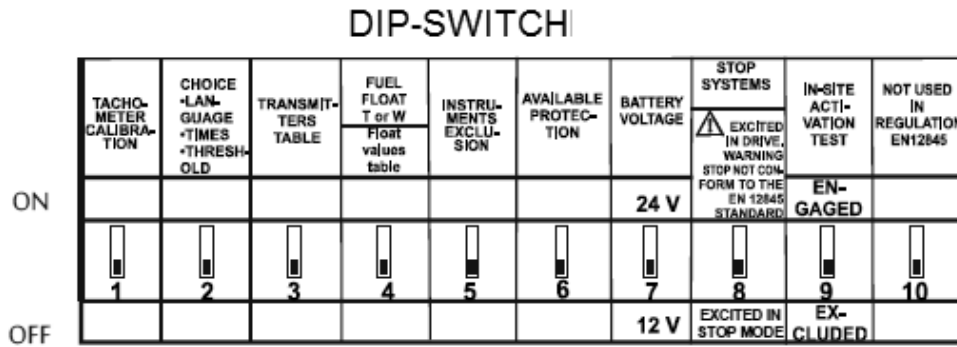

DANGER! Risk of fatal injury!

To change the DIP switch position it is necessary to open the protection on the rear side of the

electronic control inside the switchgear. The DIP switch setting must be done with the switchgear main switch QS on Fig. 14 switched OFF.

INSTRUMENTS	Push button 18 on Fig. 15 to see the values
A/B Batteries Ammeters	Full scale current 99 A connected with the battery chargers
A/B Voltmeters	For voltage from 9 up to 38 Volt connected with the battery chargers
Total /partial hour meter	Displays hours and minutes
Tachometer	Full scale 9990 rpm
Fuel level indicator	Not used – only alarm for low level
Water o oil thermometer	Displays engine oil or water temperature 30–140 °C
Oil pressure gauge	Displays engine oil pressure up to 9 bars
A/B batteries startups counter	Displays the number of startups that have occurred on each battery up to 9999

10.8 Switchgear for diesel pump – Remote alarms

Remote alarm	Description	Terminals on switch- gear	Symbol on HMI Fig. 15
Switchgear failure	It is detected when one of the fol- lowing failures occurs: • Occurred engine alarms • Mains failure on switchgear • Battery charger failure	90 – 8	17
Automatic mode switched off		90 – 91	6
Diesel pump start failure		90 – 94	23
Diesel pump in operation		90 – 92	8
Minimum fuel level		90 – 93	24

10.9 Switchgear for diesel pump – Functions

AUTOMATIC MODE SWITCHING	To switch on/off the automatic mode use selector SA1 on Fig. 14. It is possible only to remove the key from the switchgear, if the automatic mode is switched on. If the automatic mode is switched off, a flashing warning light 6 on Fig. 15 appears.
AUTOMATIC MODE	When the switchgear detects the opening of the starting call contact from the pressure switches, the pump unit starts. The control unit checks (without commanding the stopping of the motor of the pump unit) for possible engine faults during its operation. When the engine is started light 8 on Fig. 15 is turned on.
MANUAL START	This can be done in three different ways: – by means of the emergency start buttons on the switchgear – by means of the buttons START A or START B – by means of the test button with consent of the associated warning light 5 on Fig. 15 The test button receives the consent after the automatic start of the engine (activated by the call of the pressure switches) followed by a turning off or after a start failure. In both conditions the respective warning light 5 on Fig. 15 turns on. The circuit used for this function is automatically not ready for operation any more and the warning light 5 turns off when the test button is pushed and the motor is running.
AUTOMATIC START	It take place when the CALL pressure switch contacts are open which is indicated by a permanent light 9 on Fig. 15. When the pressure switches contact will be closed (pressure is replaced) the light 9 on Fig. 15 starts to flash. From this moment you can stop the engine only manually by pushing the button 7 on Fig. 15. The automatic start also takes place when the pump's priming float contact is closed, which is indicated by a permanent light 10 on Fig. 15. When the contact opens, the indicator starts flashing. Flashing lights stay on for the whole time the motor is running. In order to facilitate the start, a specific circuit makes a sequence of 6 impulses automatically alternating on batteries A and B with 15 seconds cycles (5 secs. start, 10 secs. break, both adjustable). Engine starting is interrupted if the starter motor pinion does not succeed in engaging with the crown gear of the handwheel. After the first engaging error, the starter motor makes five more engagement attempts. At the sixth failure to engage the starter motor continues to run for 5 seconds. If a battery is found not fail during start-up, it is automatically suspended and the starting cycle proceeds on the other battery. If both batteries are in faulty, the starting continues all the same until the starting failure alarm and the light 23 on Fig. 15 turn on.
DETECTION OF DIESEL ENGINE RUNNING	The diesel pump running is monitored by a magnetic sender installed on the crown gear of the engine. This function disconnects the starter motor of the engine and turns on light 8 on Fig. 15
STOP	It is possible to switch off the engine ONLY manually pushing the button 7 on Fig. 15. Warning: It is not possible to stop the motor when the call from the pressure switches is present and the automatic mode is switched on. In this case it is possible to stop the motor only by switching off the automatic mode and pushing the button 7 on Fig. 15.
PARTIAL COUNTER	Push button 18 on Fig. 15 to select the partial counter which indicates the operating hours and minutes of the last run of the diesel engine. The indicated value will be zero for the next start of the engine.
BATTERY CHARGING	The automatic battery charging is managed by checking the current value for the fast charge and checking the voltage value for the maintenance charge. The following failures: • Battery A and/or broken fuse • Battery B and/or broken fuse • Short-circuit on A/B battery cables • Mains failure on battery charges A/B are indicated by the warning lights 17 and 15 on Fig. 15.
BATTERIES CHECK	A special circuit checks the efficiency of the batteries, especially during the engine starting phase. In case of failure on the batteries A or B the light 22 on Fig. 15 turns on.

ALARMS	<p>The alarms are indicated on the HMI on Fig. 15 by the respective lights plus a flashing cumulative light 17 on Fig. 15</p> <ul style="list-style-type: none"> • Stored alarms : inefficiency of batteries A /B light 22, low oil pressure light 1, pick-up failure and generator failure light 3 , Overheating light 2 on Fig. 15 • Non-stored alarms: minimum fuel level light 24 , mains failure on the battery charges light 15, pick-up interrupted, oil/water heater failure light 4 on Fig. 15
START FAILURE	<p>This function stops the start attempts. If the engine does not start after the sixth attempt the light 23 on Fig. 15 turns on and the starting cycle is interrupted. To restart the engine it is necessary to reset the system by pushing the button 13 on Fig. 15.</p>
COMMISSIONING TEST ONSITE	<p>To complete the commissioning test onsite</p> <ol style="list-style-type: none"> 1. Fix the stop lever on the engine Fig. 11 by means of a strap 2. Change the position of the DIP switch 9 on Fig. 16 to ON 3. Push the button 11 on Fig. 15 for at least 3 seconds <p>A dedicated circuit starts with 6 alternate impulses on the batteries A and B for a 30 seconds cycle (15 seconds for the start attempt and a 15 second break). After 6 cycles, the start failure alarm light 23 on Fig. 15 turns on. Restore the stop lever on the engine by removing the strap and push the manual start test button 5 on Fig. 15. The engine starts. After a while stop the engine. The test is completed. Change the position on the DIP switch 9 on Fig. 16 to OFF.</p>
LIGHT TEST	<p>Keep the button 18 on Fig. 15 pushed to check the lights.</p>

10.10 Switchgear for jockey pump

Fig. 17

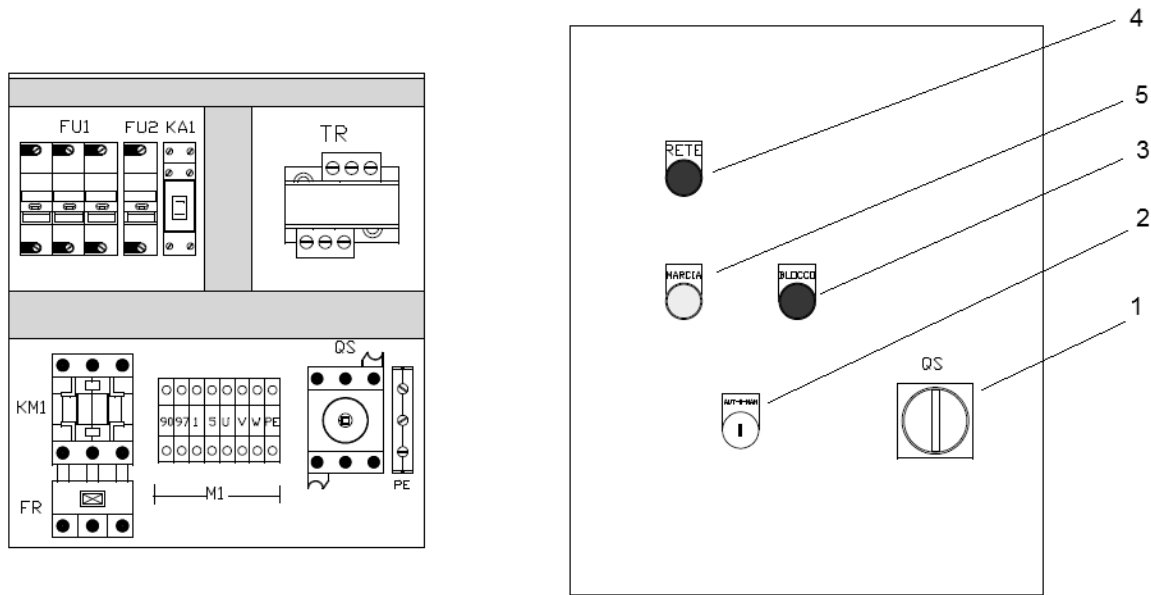

Description

QS – 1	Door locking switch
KM1	Contactor
FR	Overload relay
FU	Fuses
KA1	Auxiliary relay
TR	Power transformer
2	Selector switch Automatic/Off/Manual
3	Overload alarm light
4	Main power light
5	Pump running alarm light

10.11 Switchgear for jockey pump – Remote alarms

Remote alarm	Description	Terminals on switch-gear
Overload	The jockey pump is blocked because of overload	90 – 97

10.12 Switchgear for jockey pump – Functions

AUTOMATIC MODE SWITCHING	To switch on/off the automatic mode use the selector switch 2 on Fig. 17.	
AUTOMATIC MODE	If the switchgear detects the closing of the starting call contact from the pressure switch, the pump starts. If the pressure is replaced in the plant, the pressure switch opens the contact and the pump stops.	
MANUAL START/STOP	To start/stop the jockey pump manually, switch on/off the manual mode on the selector switch 2 on Fig. 17.	

11 Faults, causes and remedies

The procedures indicated in the table below must be carried out **ONLY** by expert personnel. Never carry out any work without having carefully read and understood this manual. Never attempt to carry out repairs of materials and equipment without a fully and correctly understanding of them.

If people do not have sufficient knowledge about the product and the operating logic required by specific standards respective to the fire extinguishing systems, or if people do not have the needed technical skills, contact Wilo to make regular maintenance checks.

Faults	Causes	Remedies
The switchgear is off	No power supply	Make sure that the supply line is connected and voltage is present
	Out-of-order fuses	Check and/or change fuses. Check and/or replace the switchgear
	Auxiliary circuit failing	Check voltage of primary and secondary circuits in the transformer. Check and/or replace fuses of the transformer
Motor does not start	No power supply	Check connections and electric switch-gear
	Short-circuit in winding	Check windings of motor
	Switchgear faulty/wrong connections	Check connections
	Overload	Check the sizing of the supply line. Make sure that the pump is not blocked
Pump works, but does not supply water or has a low flow/head	Wrong direction of rotation	Invert two of the motor supply phases.
	Pump cavitation due to excessive suction depth	Review calculations to suit pumps NPSHr
	Pump cavitation due to wrong diameter of the suction pipe and valves	Review calculations to suit pumps NPSHr
	Air inlet in the suction line	Make sure that there are no leaks in the suction line. Check the distance between the suction points if several pumps are installed. Fit anti-vortex plates
	Valves partially/totally closed	Open suction and discharge valves.
	Pump worn out	Check and repair
	Pump rotor obstructed	Check and repair
	Strainer / filters obstructed	Check and repair
	Coupling between pump and motor worn out	Check and repair
	Motor fails to reach nominal speed or vibrates	Check speed See above
	Pump bearings are worn out or not lubricated	Lubricate with lubricators

Faults	Causes	Remedies
Motor fails to reach nominal speed	Voltage at motor terminals too low	Check power supply voltage, connections and the cross-section of the cables in the power line.
	False contacts in the power contactor or problems with the start device	Check and repair
	Phase failure	Check line, connection and fuses
	False contacts in power supply cables	Check terminal fixing
	Winding to the earth or short-circuit	Dismantle the motor, repair or replace it
Non-operating pumps suddenly started	Incorrect sizing of power line	Check and replace
	Insufficient voltage	Check power supply
	Pump sizing	Remove the rotating parts then check
Presence of voltage on motor housing	Contact between line cables and earth	Correct connections
	Humid or old insulation	Wipe motor or re-wind it.
	Short-circuit between terminals and external housing	Check insulation between terminals and housing.
Unusual overheating of the exterior of motor	Pump overload	Dismantle and check
	Coupling out of axis	Align correctly
	Ambient temperature beyond 40 °C	Ventilate the space
	Voltage higher/lower than nominal value	Check up stream power supply
	Phase failure	Check power supply and fuses
	Insufficient ventilation	Check strainers and pipes. Resize
	Sliding between stator and rotor	Repair or replace the motor
	Unbalanced voltage on three phases	Check power supply
Main pump starts before jockey pump	Pressure switch on the main pump is calibrated at a higher value than the jockey pump	Check pressure switch settings
Main pump starts immediately with inhibition indicator in position 1	Pressure switch calibrated at a lower value than the system pressure	Check pressure switch settings Increase the pressure level in the installation
	Water level in the priming tank is too low	Check level of priming tank
Sudden speed drop	Instantaneous overload/foreign part in pump	Dismantle pump
	Single-phase operation	Check supply and fuses
	Voltage drop	Check supply
Magnetic noise Sudden whistling	Motor winding or short-circuit	Dismantle the motor, then repair or replace it.
	Friction between stator and rotor	Dismantle the motor, then repair or replace it.
Mechanical noise	Loosened screws	Check and tighten
	Loosened screws in the fan cover cap/coupling cover cap	Check and tighten
	Sliding between fan and motor, and between coupling and coupling cover cap etc.	Guarantee the correct distance and re-assemble.
	Foreign parts in motor or pump	Dismantle and remove
	Not aligned coupling	Re-align
	Bearings insufficiently lubricated/worn out/broken	Lubricate or replace
Overheating of pump/motor bearings	Bearings are damaged	Replace
	Insufficient lubrication	Lubricate again
	Pump and motor are not aligned	Re-align
Unusual vibrations	No vibration-damping sleeve devices on the unit	Install or repair
	Pump cavitation	Review the dimensioning of installation
	Too much air in the water	Make sure that there are no leaks in the suction line. Check the distance between the suction points if several pumps are installed. Fit anti-vortex plates
	Bearings, pump/motor shaft are worn out	Replace
	Pump/motor coupling is worn out	Replace
	Pump and motor are not aligned	Re-align

Faults	Causes	Remedies
Motor does not stop after using of stop button	This is normal if plant pressure is not restored	Stop the automatic mode, then stop the pump
	Switchgear failure	Switch off the switchgear, then check
	Failure of electromagnet for stopping diesel pump switchgear	Use the fuel lever on which the electromagnet works manually
Engine fails to reach nominal speed or oscillates	Accelerator lever in wrong position	Check and adjust RPM and secure lever
	Dirty fuel strainer	Clean or replace
	Faulty injector/pump	Contact the Wilo customer service
The starter pinion does not remove after starting the engine	Speed counter failure	Check the distance from wheel. Replace.
	Failure of switchgear on switchgear	Contact the Wilo customer service
Engine does not start or tries to start and stops then	Unloaded batteries	Check battery and battery charger. Load battery and replace it if necessary
	Lack of fuel	If it is not indicated on the switchgear's indicating light, check the fuel tank and alarm float. Replace the tank
	Air in fuel circuit	Remove air from circuit by draining the injectors and diesel fuel strainers.
	Dirty fuel strainer	Replace
	Dirty air strainer	Replace
	Fuel circuit failure: injectors blocked, injection pump failure	Contact the Wilo customer service
	Too low temperature	Check that the ambient temperature is not less than 10 °C. Then check the correct working of oil/water heater. Replace
	Loosened or rusty connections between battery/starter/relay	Check cables and terminals. Re-wire. Tighten correctly. Replace
	Diesel pump switchgear failure	Check and replace if necessary
	Starter failure	Contact the Wilo customer service
	Black smoke	Dirty/blocked air strainer
Too high oil level		Remove oil excess
Problem with injector, fuel pump, etc.		Contact the Wilo customer service
Unusual heating – too high water/oil temperature	Pump overload (frictions)	Dismantle and check
	Coupling out of axis	Align correctly
	Ambient temperature beyond 40 °C	Ventilate the space
	Insufficient ventilation	Check filters and ventilation grille. Clean or resize
	Dirty or blocked radiator/coolant	Dismantle and clean
	Lack of water in radiator/heat exchanger	After the cooling, fill with water and check for if leaks are present.
	Heat exchanger circuit valve closed or insufficiently open	Check that pump has a water flow, then open the butterfly valve.
	Water circulation pump failure	Contact the Wilo customer service
	Fan belt failure (air-cooled engines)	Check voltage and replace if necessary
	Corresponding alarm failure	Check sensor, connections and control unit on switchgear. Replace if necessary.
	Jockey pump does not start	No power supply
The pressure switch is calibrated to a lower pressure than the main pump.		Check the pressure switch settings.
Short-circuit in winding		Check winding
Intervention of the thermal protection		Check the sizing of the supply line. Check that the pump is not blocked, then check pressure switch setting and the tank inflation.
Switchgear failure and wrong connections.		Check

12 Decommissioning and removal

If the system needs to be decommissioned, first disconnect the unit from the power supply and water circuit, and then separate the different materials of the unit in order to eliminate them separately.

Use public or private waste management companies for the disposal of the product or components.

Check that there are no residues of any polluting liquids inside the pump and pipes.

The unit equipped with diesel motor may have batteries which contain lead and electrolytic liquid including acids, solutions of water and antifreeze liquid, oil and fuel.

Pay particular attention to the elimination of batteries and make all actions necessary to prevent any spillage of liquid on the ground that can pollute the environment.

If materials of the unit are spread in the environment, they can create serious environmental damages.

All materials and components must be collected, and eliminated in accordance with the regulations in force. Even during the installation operations and handling, the following materials must be sent to centres specialised in the collection and removal of waste:

- Electromechanical and electronic components
- Electric cables
- Batteries
- Strainers
- Oil drain
- Mix of water and antifreeze
- Rags and smooth material used for various operations or cleaning
- Materials for packaging

Liquids and polluting materials must be eliminated according to the specific standards in force.

Make a separated elimination allow to retrieve equipment, and to reduce pollution.

13 Spare parts

For rapid intervention and recovery of the fire extinguishing system and according to the type of pumping conditions, it is advisable to have a minimum amount of spare parts in stock, such as:

Main electric pump

Complete mechanical seal, protection fuses, starting pressure switch, step relay coil.

Main diesel pump

Complete mechanical seal, protection fuses, starter kit, oil heater, starting pressure switch, two fuel strainers, two oil strainers, two sets of straps, two injector nozzles for diesel engine, a complete set of connections, gear and oil and fuel circuit hoses, tools recommended by the manufacturer of diesel engine.

Electric jockey pump

Complete mechanical seal, protection fuses and starting pressure switch.

wilo

Pioneering for You