

Wilo-FLA



de Einbau- und Betriebsanleitung
en Installation and operating instructions
fr Notice de montage et de mise en service

nl Inbouw- en bedieningsvoorschriften

Fig. 1a:

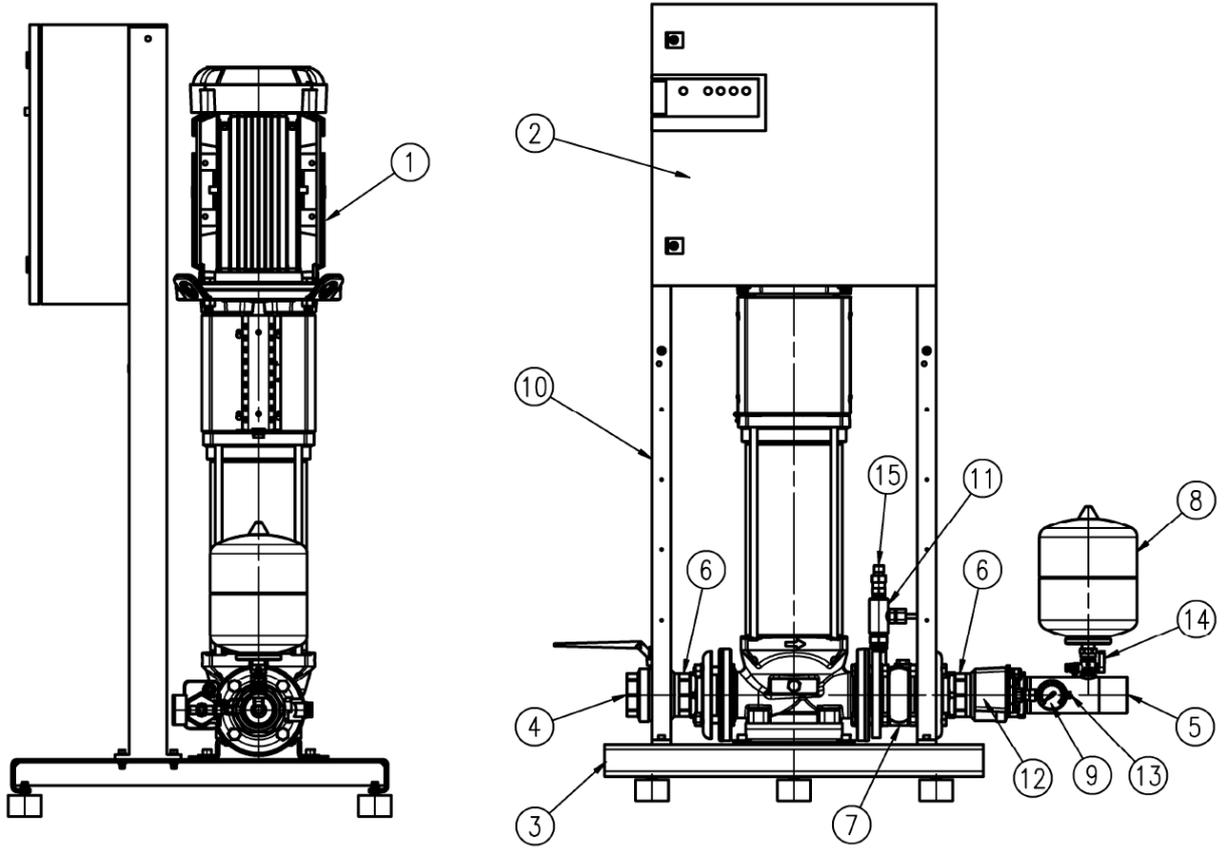

Fig. 1b:

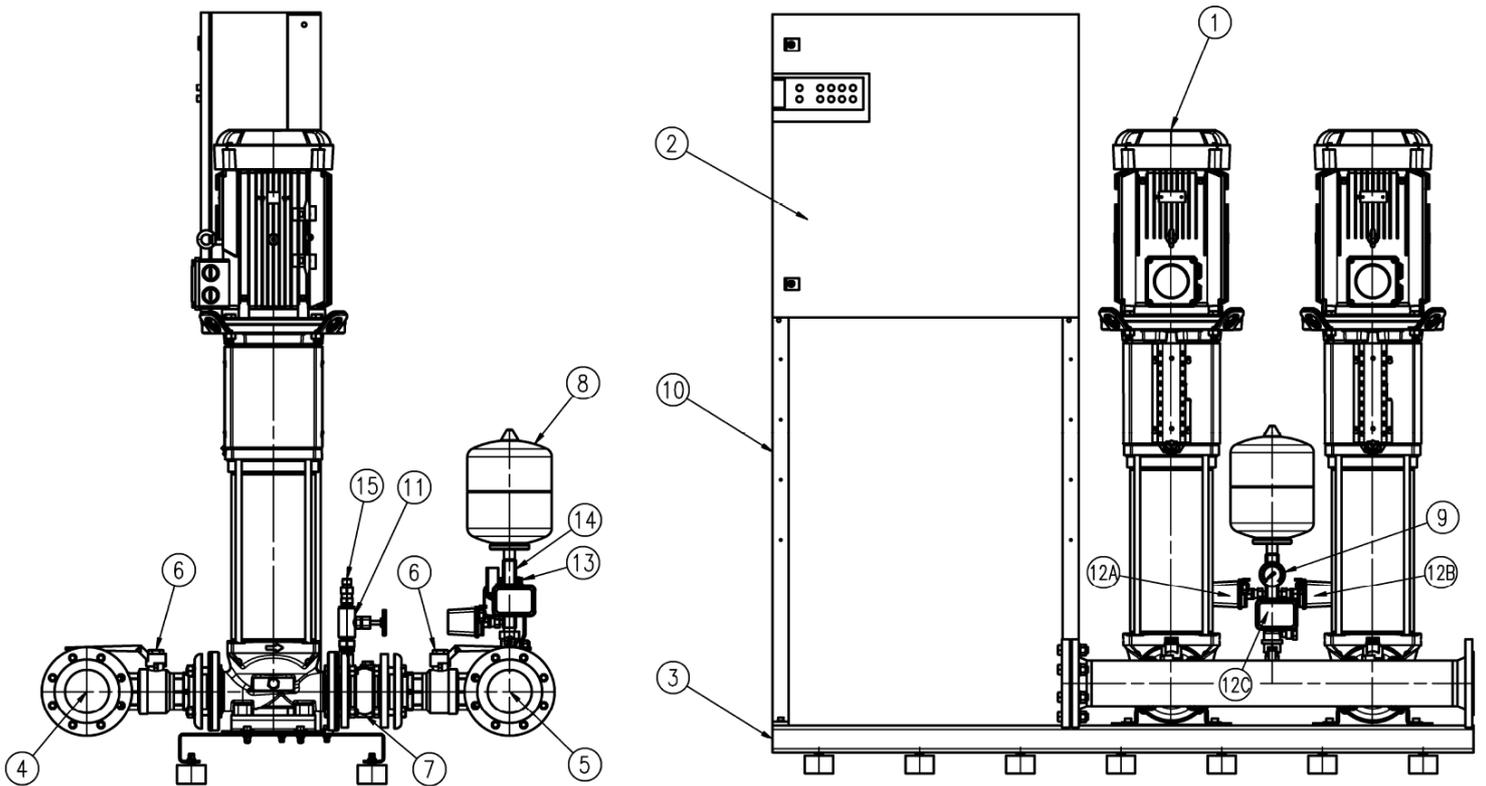

Fig. 2a:

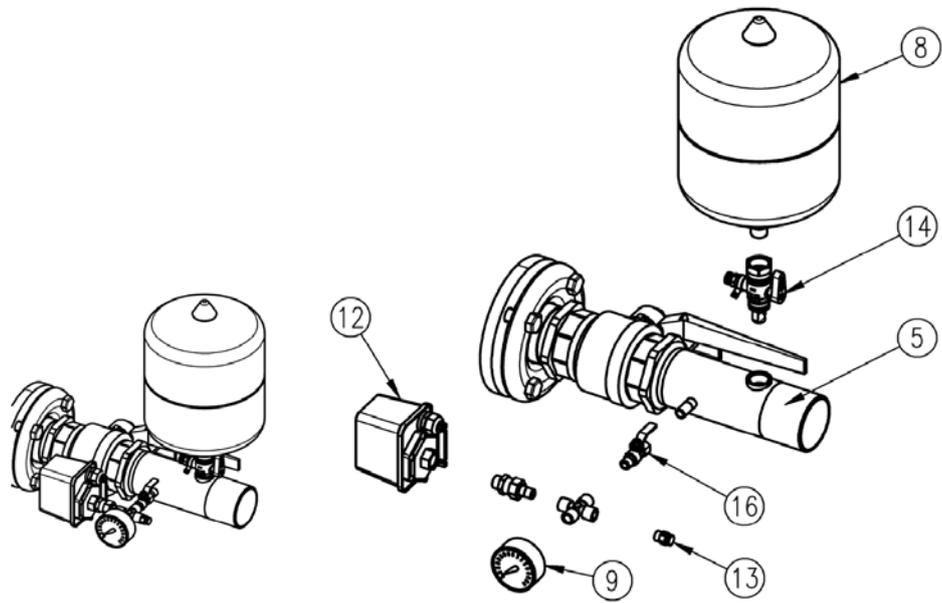

Fig. 2b:

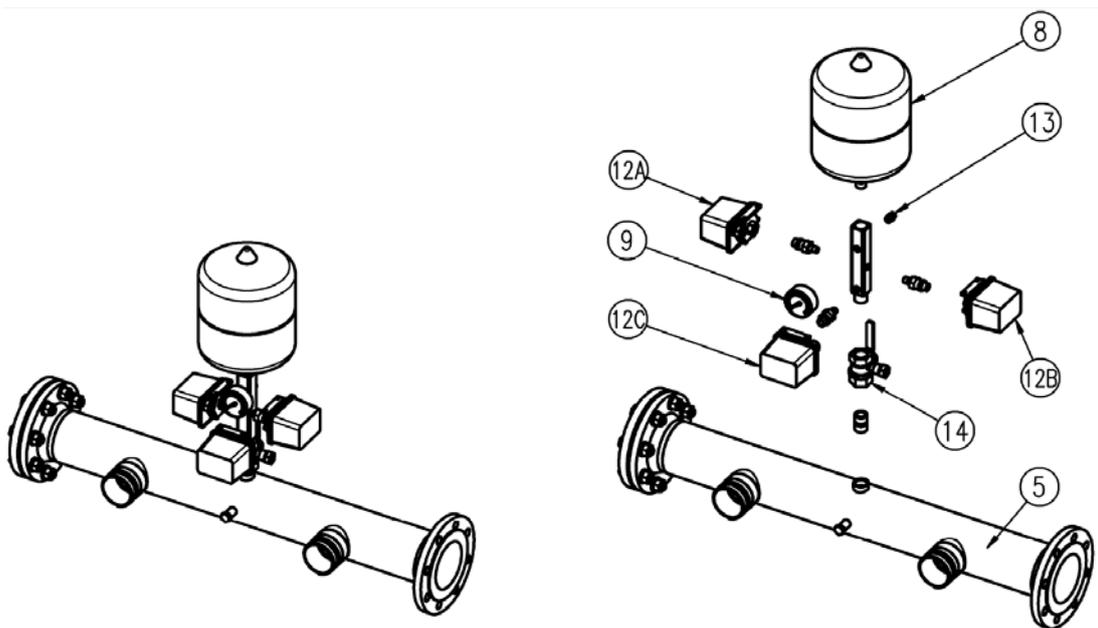

Fig. 3:

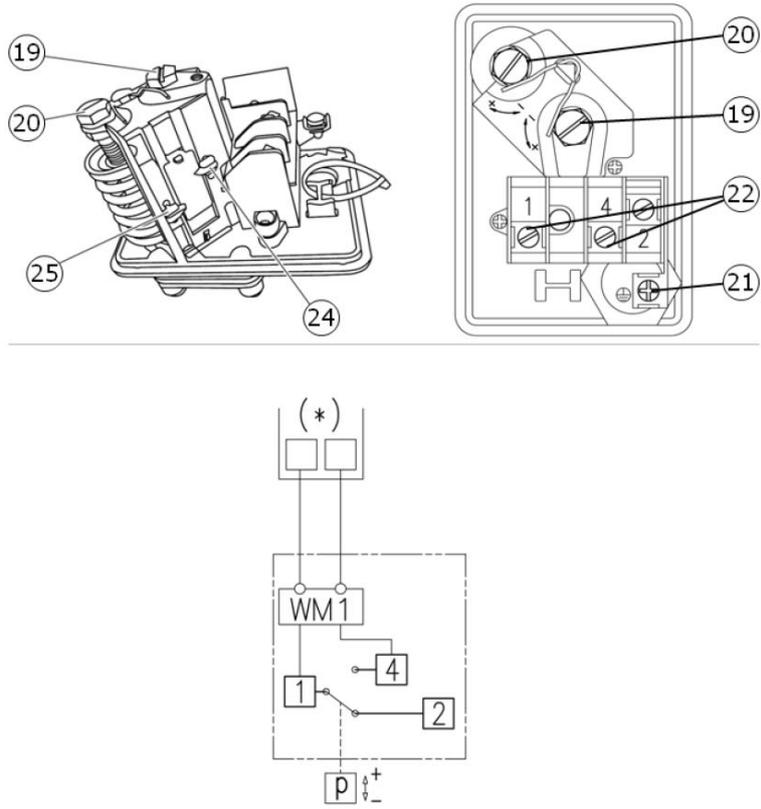

Fig. 4:

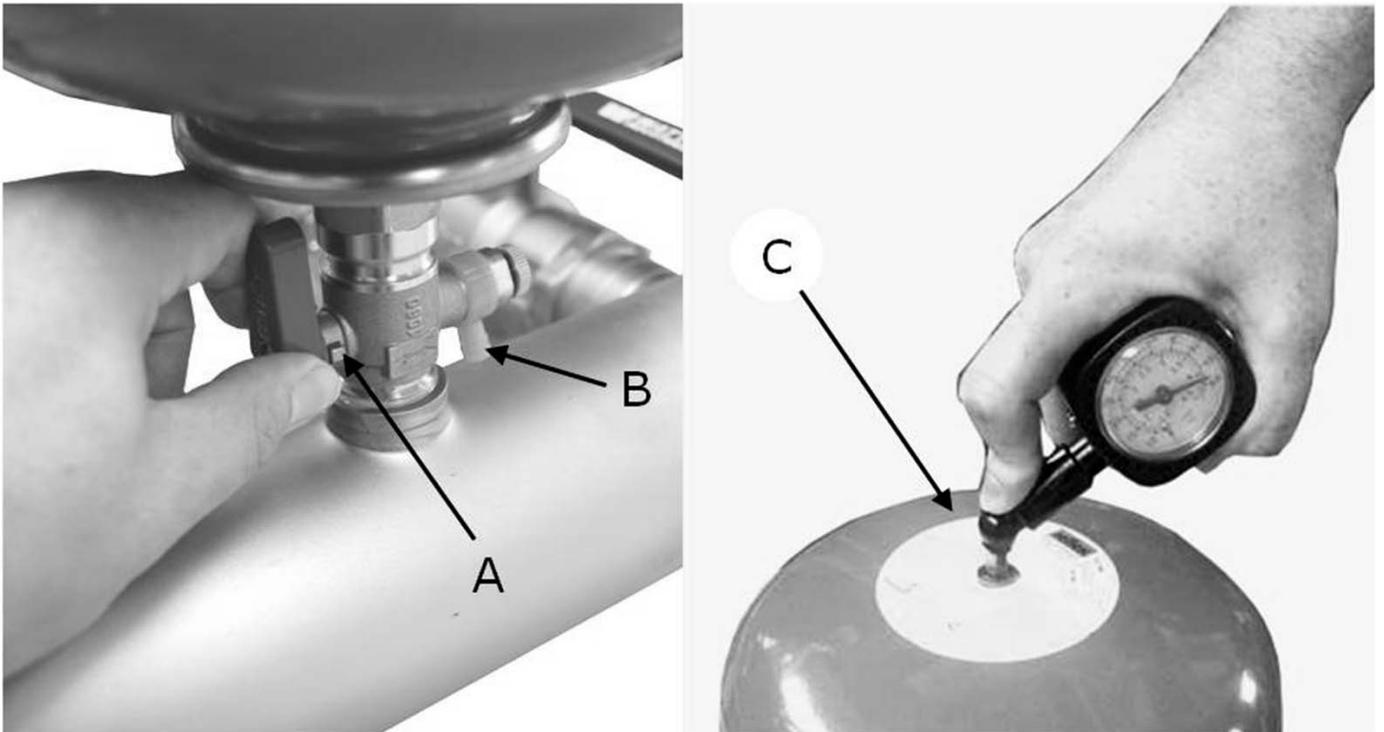

Fig. 5:

Hinweis / advice / attention / atención

a → Stickstoffdruck entsprechend der Tabelle / Nitrogen pressure according to the table
 Pression d'azote conformément au tableau / Presión del nitrógeno según la tabla

b → **PE [bar]** Einschaltdruck / starting pressure / Pression de démarrage / Comenzar la presión

c → **PN₂ [bar]** Stickstoffdruck / Nitrogen pressure / Pression d'azote / Presión del nitrógeno

| | | | | | | | | | | | | |
|-----------------|-----|-----|-----|-----|-----|-----|-----|-----|-----|-----|-----|-----|
| PE | 2 | 2,5 | 3 | 3,5 | 4 | 4,5 | 5 | 5,5 | 6 | 6,5 | 7 | 7,5 |
| PN ₂ | 1,8 | 2,3 | 2,8 | 3,2 | 3,7 | 4,2 | 4,7 | 5,2 | 5,7 | 6,1 | 6,6 | 7,1 |

| | | | | | | | | | | | | |
|-----------------|-----|-----|-----|-----|-----|------|------|------|------|------|------|------|
| PE | 8 | 8,5 | 9 | 9,5 | 10 | 10,5 | 11 | 11,5 | 12 | 12,5 | 13 | 13,5 |
| PN ₂ | 7,5 | 8 | 8,5 | 9 | 9,5 | 10 | 10,5 | 11 | 11,5 | 12 | 12,5 | 13 |

1bar = 100000Pa = 0,1MPa = 0,1N/mm² = 10200kp/m² = 1,02kp/cm²(at) = 0,987atm = 750Torr = 10,2mWs

d → Stickstoffmessung ohne Wasser / Nitrogen measurement without water /
 Mesure d'azote hors eau / Medida del nitrógeno sin el agua

e → **Achtung: Nur Stickstoff einfüllen / Note: Only fill in nitrogen /**
Nota: Remplir Seulement à l'azote / Nota: Completar solamente el nitrógeno

Fig. 6a:

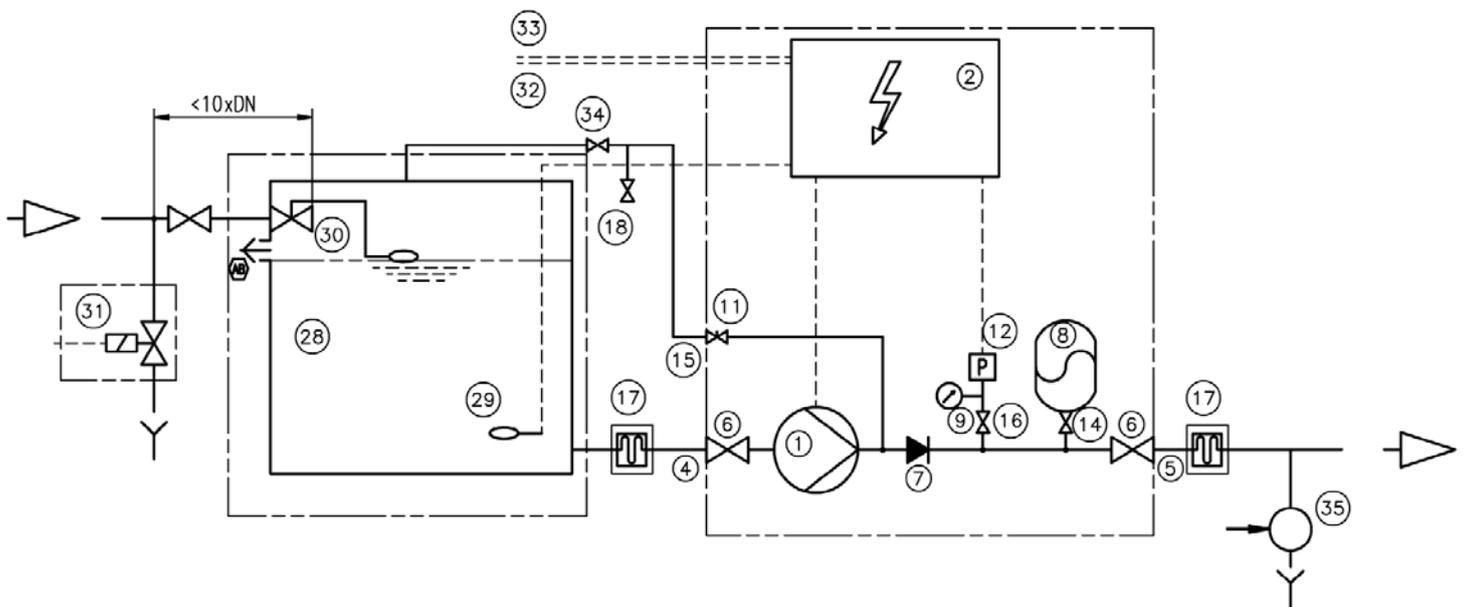

Fig. 6b:

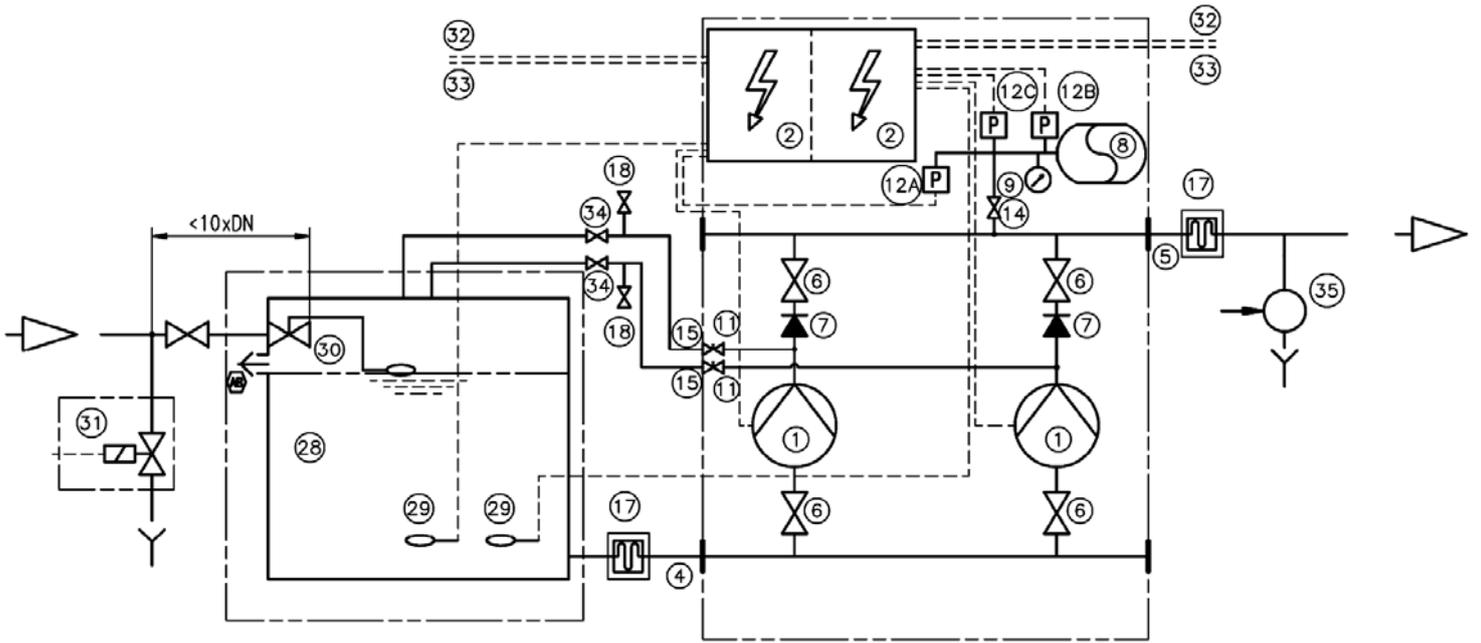
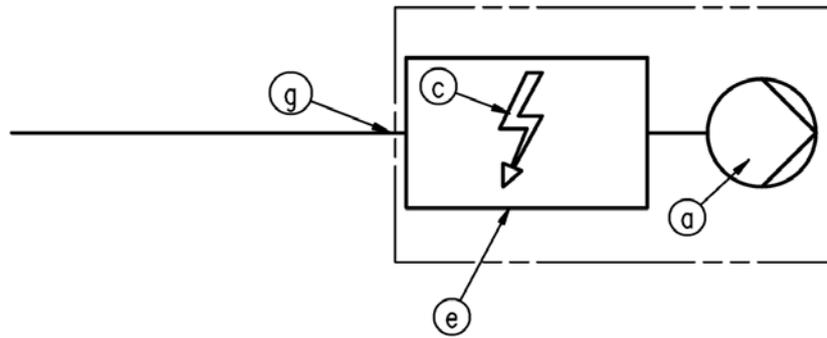
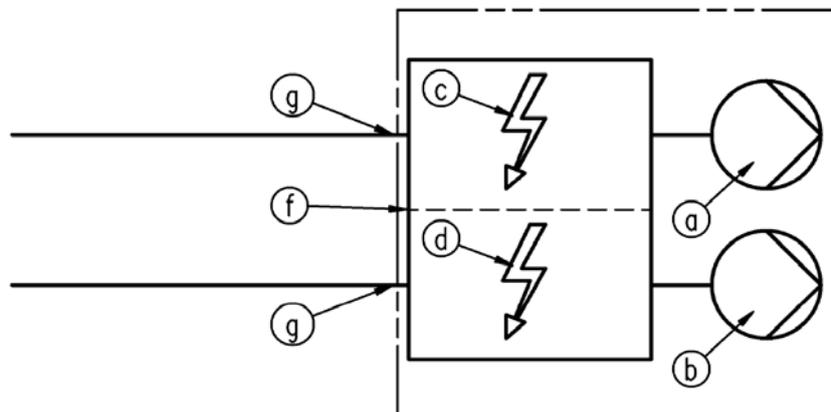

Fig. 7a:



*

Fig. 7b:



*

Fig. 8a:

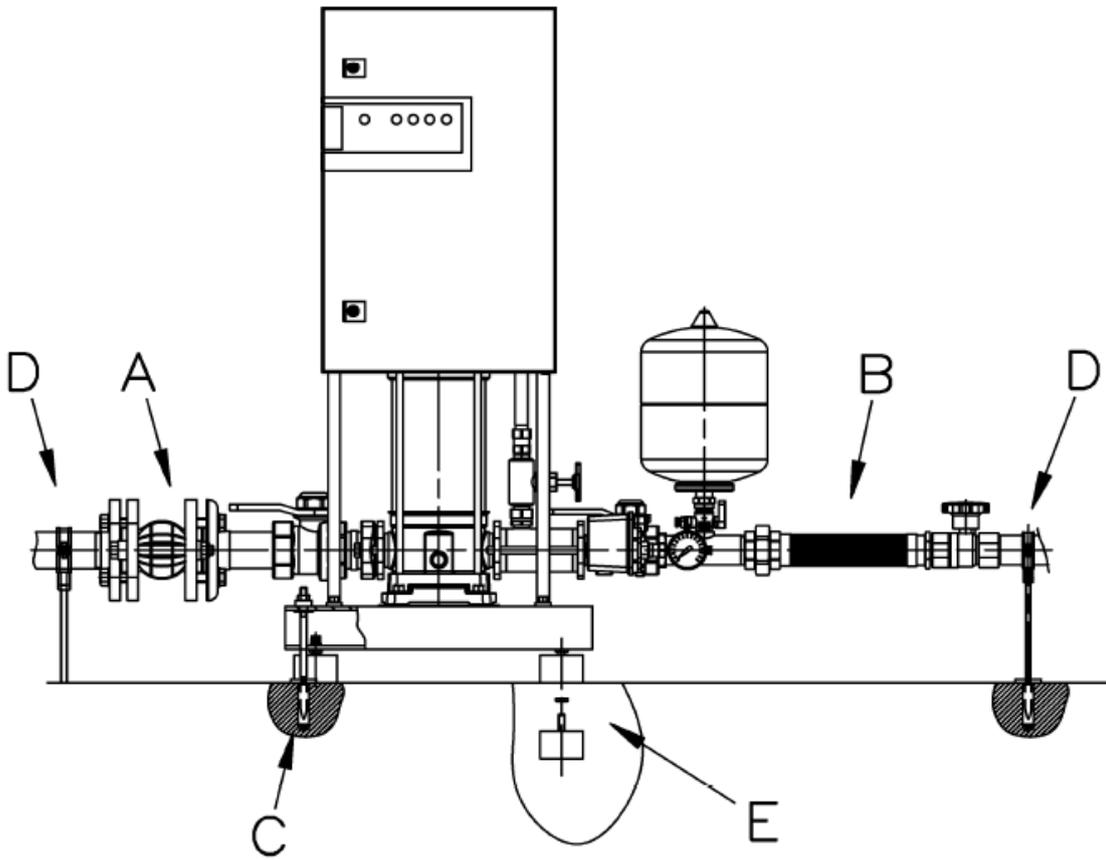
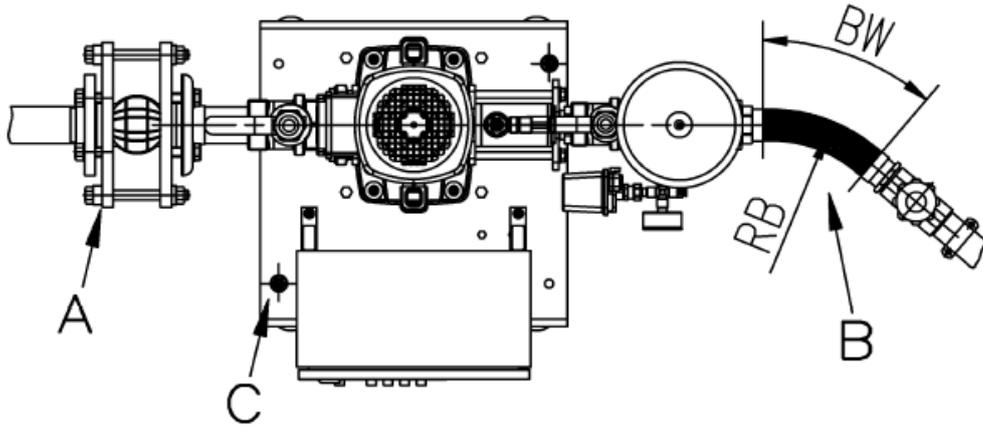

Fig. 8b:

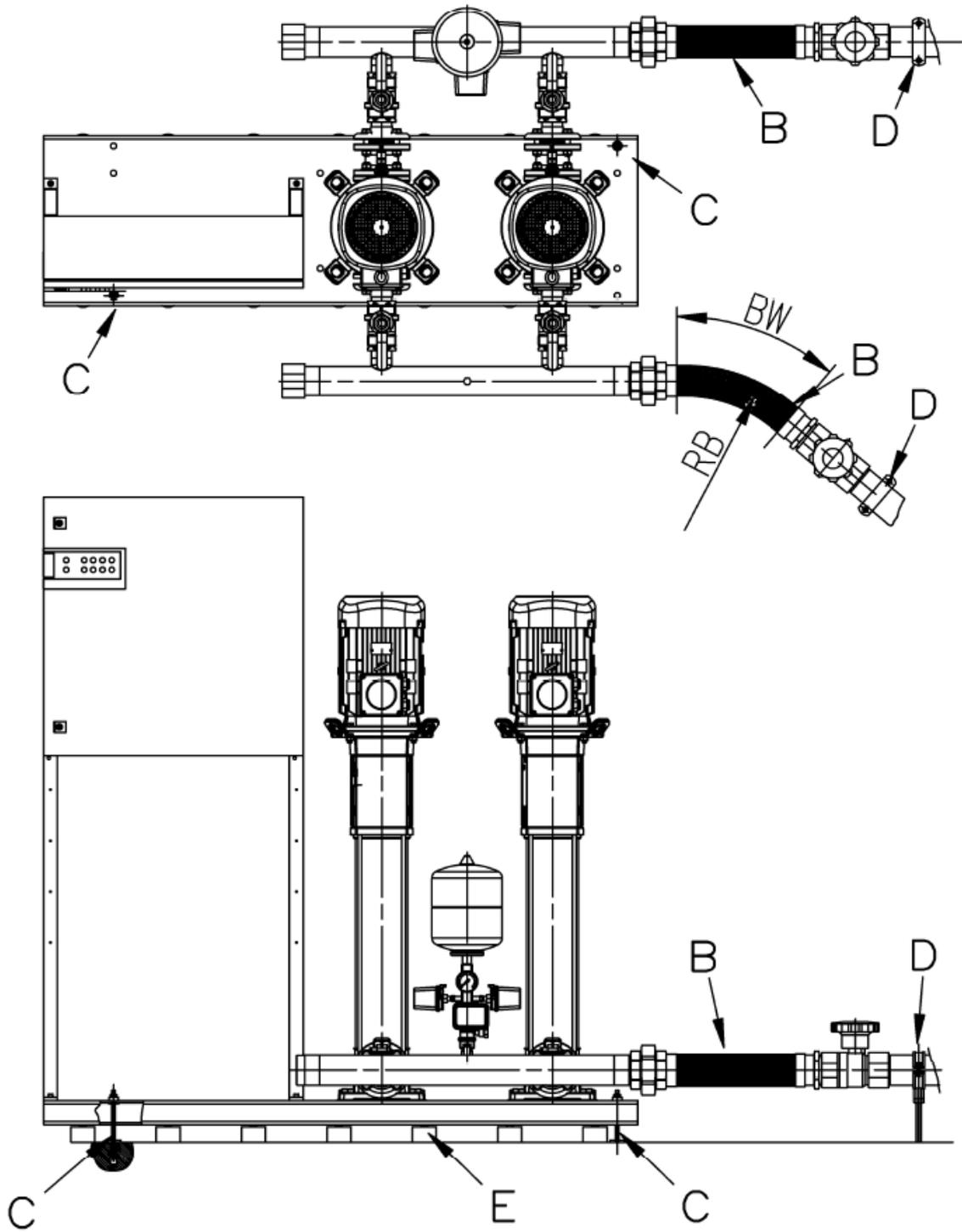
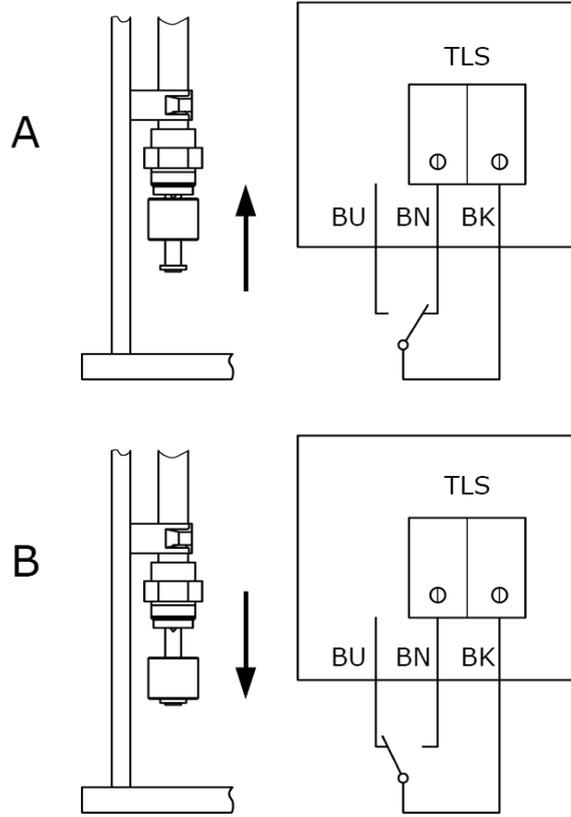

Fig. 9:



Captions

| Fig. 1a | Example of FLA-1HELIX V..... |
|---------|--|
| Fig. 1b | Example of FLA-2HELIX V..... |
| 1 | Pump |
| 2 | Control device |
| 3 | Base frame |
| 4 | Inlet connection/inlet collecting pipe |
| 5 | Pressure connection/pressure collecting pipe |
| 6 | Check valve |
| 7 | Non-return valve |
| 8 | Diaphragm pressure vessel |
| 9 | Pressure gauge |
| 10 | Standkonsole |
| 11 | Needle-type throttle |
| 12 | Pressure switch |
| 12A | Pressure switch 1 |
| 12B | Pressure switch 2 |
| 12C | Pressure switch 3 |
| 13 | Draining/venting |
| 14 | Throughflow fitting/check valve |
| 15 | Bypass connection (on the pressure side) |

| Fig. 2a | FLA-1 pressure switch and diaphragm pressure vessel kit |
|---------|---|
| 5 | Pressure connection/pressure collecting pipe |
| 8 | Diaphragm pressure vessel |
| 9 | Pressure gauge |
| 12 | Pressure switch |
| 13 | Draining/venting |
| 14 | Throughflow fitting/check valve |
| 16 | Stop valve |

| Fig. 2b | FLA-2 pressure switch and diaphragm pressure vessel kit |
|---------|---|
| 5 | Pressure connection/pressure collecting pipe |
| 8 | Diaphragm pressure vessel |
| 9 | Pressure gauge |
| 12A | Pressure switch |
| 12B | Pressure switch 2 |
| 12C | Pressure switch 3 |
| 13 | Draining/venting |
| 14 | Throughflow fitting/check valve |
| 16 | Stop valve |

| Fig. 3 | Pressure switch, type FF (change over contact) |
|--------|---|
| 19 | Adjusting screw for deactivation pressure (upper switching point) |
| 20 | Adjusting screw for differential pressure (lower switching point) |
| 21 | Earth connection (PE) |
| 22 | Terminal block/contacts |
| 24 | Scale for switch-off pressure |
| 25 | Scale for differential pressure |

| Fig. 4 | Operation of throughflow fitting/pressure test Diaphragm pressure vessel |
|--------|--|
| A | Opening/closing |
| B | Drain |
| C | Checking the supply pressure |

| Fig. 5 | Reference table for nitrogen pressure Diaphragm pressure vessel (example) |
|--------|---|
| a | Nitrogen pressure according to the table |
| b | Switch-on pressure, base-load pump, in bar PE |
| c | Nitrogen pressure in bar PN2 |
| d | Nitrogen measurement without water |
| e | Important! Introduce nitrogen only |

| Fig. 6a | FLA-1 hydraulic diagram |
|---------|--|
| Fig. 6b | FLA-1 hydraulic diagram |
| 1 | Pump |
| 2 | Control device |
| 4 | Inlet connection/inlet collecting pipe |
| 5 | Pressure connection/pressure collecting pipe |
| 6 | Check valve |
| 7 | Non-return valve |
| 8 | Diaphragm pressure vessel |
| 9 | Pressure gauge |
| 11 | Needle-type throttle |
| 12 | Pressure switch |
| 12A | Pressure switch 1 |
| 12B | Pressure switch 2 |
| 12C | Pressure switch 3 |
| 14 | Throughflow fitting/check valve |
| 15 | Bypass connection (on the pressure side) |
| 17 | Flexible connection (e.g. WILO compensator, WILO flexi hose) |
| 18 | Spur line for calibration |
| 28 | WILO break tank |
| 29 | Low-water signal transmitter |
| 30 | WILO float valve |
| 31 | WILO automatic flushing apparatus |
| 32 | External command device (e.g. limit switch) |
| 33 | Signal(s) to BMS |
| 34 | Outlet valve in bypass passage |
| 35 | Outside water supply for fire brigade |

| Fig. 7a | Example of FLA-1 electrical connection |
|---------|---|
| Fig. 7b | Example of FLA-2 electrical connection |
| * | Site circuit protection according to DIN 14462 |
| a | Pump 1 |
| b | Pump 2 |
| c | Control of pump 1 |
| d | Control of pump 2 |
| e | Switch cabinet as per DIN14462 with one power supply |
| f | Switch cabinet as per DIN14462 with two power supplies |
| g | Onsite power supply (including network switching, if necessary) |

| Fig. 8a | FLA-1 installation example |
|---------|--|
| Fig. 8b | FLA-2 installation example |
| A | Expansion joint with extension limiters (accessory) |
| B | Flexible connection line (accessory) |
| C | Floor fixation with structure-borne noise insulation (by the customer) |
| D | Fixation of pipes, e.g. with pipe clips (by the customer) |
| E | Screw the vibration dampers (included in scope of delivery) into the threaded inserts provided and secure them with counter nuts |
| BW | Bend angle for flexible connection line |
| RB | Bend radius for flexible connection line |

| Fig. 9 | Low-water signal transmitter (float switch) break tank |
|--------|---|
| A | Tank full, contact closed |
| B | Tank empty, contact open |
| BN | Brown |
| BU | Blue |
| BK | Black |
| TLS | Contacts in the control device for low-water signal transmitter |

| | | |
|-----------|---|-----------|
| 1 | General | 27 |
| 2 | Safety | 27 |
| 2.1 | Indication of instructions in the operating instructions | 27 |
| 2.2 | Personnel qualifications | 27 |
| 2.3 | Danger in the event of non-observance of the safety instructions | 27 |
| 2.4 | Safety consciousness on the job | 27 |
| 2.5 | Safety instructions for the operator | 27 |
| 2.6 | Safety instructions for installation and maintenance work | 28 |
| 2.7 | Unauthorised modification and manufacture of spare parts | 28 |
| 2.8 | Improper use | 28 |
| 3 | Transport and interim storage | 28 |
| 4 | Intended use | 29 |
| 5 | Product information | 29 |
| 5.1 | Type key | 29 |
| 5.2 | Technical data | 30 |
| 5.3 | Scope of delivery | 30 |
| 5.4 | Accessories | 30 |
| 6 | Description of the product and accessories | 31 |
| 6.1 | General description | 31 |
| 6.2 | Components of the fire extinguishing system in accordance with DIN14462 (FLA) | 31 |
| 6.3 | Function of the fire extinguishing system in accordance with DIN14462 (FLA) | 32 |
| 6.4 | Special requirements of DIN14462 | 33 |
| 6.4.1 | Shut-off devices | 33 |
| 6.4.2 | Minimum extraction amount | 33 |
| 6.4.3 | FLA switchgear | 33 |
| 6.5 | Noise | 33 |
| 7 | Setup/installation | 33 |
| 7.1 | Installation site | 33 |
| 7.2 | Installation | 33 |
| 7.2.1 | Foundation/bearing surface | 33 |
| 7.2.2 | Hydraulic connection and pipes | 33 |
| 7.2.3 | Diaphragm pressure tank (accessory) | 34 |
| 7.2.4 | Safety valve (accessory) | 34 |
| 7.2.5 | Non-pressurised break tank (accessory) | 34 |
| 7.2.6 | Expansion joints (accessories) | 34 |
| 7.2.7 | Flexible connection lines (accessory) | 35 |
| 7.3 | Electrical connection | 35 |
| 8 | Commissioning/decommissioning | 36 |
| 8.1 | General preparations and control measures | 36 |
| 8.1.1 | Set values for the pressure switch | 37 |
| 8.1.2 | Setting the needle-type throttles in the bypass | 38 |
| 8.2 | Commissioning the system | 40 |
| 8.3 | Decommissioning the system | 40 |
| 9 | Maintenance | 40 |
| 10 | Faults, causes and remedies | 41 |
| 11 | Spare parts | 43 |

1 General

About this document

The language of the original operating instructions is German. All other languages of these instructions are translations of the original operating instructions.

These installation and operating instructions are an integral part of the product. They must be kept readily available at the place where the product is installed. Strict adherence to these instructions is a precondition for the proper use and correct operation of the product.

These installation and operating instructions correspond to the relevant version of the product and the underlying safety standards valid at the time of going to print.

EC declaration of conformity:

A copy of the EC declaration of conformity is a component of these operating instructions. If a technical modification is made on the designs named there without our agreement, this declaration loses its validity.

2 Safety

These operating instructions contain basic information which must be adhered to during installation, operation and maintenance. For this reason, these operating instructions must, without fail, be read by the service technician and the responsible specialist/operator before installation and commissioning.

It is not only the general safety instructions listed under the main point "safety" that must be adhered to but also the special safety instructions with danger symbols included under the following main points.

2.1 Indication of instructions in the operating instructions



Symbols:
General danger symbol



Danger due to electrical voltage



NOTE

Signal words:

DANGER!

Acutely dangerous situation.

Non-observance results in death or the most serious of injuries.

WARNING!

The user can suffer (serious) injuries. 'Warning' implies that (serious) injury to persons is probable if this information is disregarded.

CAUTION!

There is a danger of damaging the product/system. 'Caution' implies that damage to the product is likely if this information is disregarded.

NOTE:

Useful information on handling the product. It draws attention to possible problems. Information that appears directly on the product, such as:

- Direction of rotation arrow
- Identification for connections
- Rating plate
- Warning sticker

Must be strictly complied with and kept in legible condition.

2.2 Personnel qualifications

The installation, operating and maintenance personnel must have the appropriate qualifications for this work. Area of responsibility, terms of reference and monitoring of the personnel are to be ensured by the operator. If the personnel are not in possession of the necessary knowledge, they are to be trained and instructed. This can be accomplished if necessary by the manufacturer of the product at the request of the operator.

2.3 Danger in the event of non-observance of the safety instructions

Non-observance of the safety instructions can result in risk of injury to persons and damage to the environment and the product/unit. Non-observance of the safety instructions results in the loss of any claims to damages.

In detail, non-observance can, for example, result in the following risks:

- Danger to persons from electrical, mechanical and bacteriological influences
- Damage to the environment due to leakage of hazardous materials
- Property damage
- Failure of important product/unit functions
- Failure of required maintenance and repair procedures

2.4 Safety consciousness on the job

The safety instructions included in these installation and operating instructions, the existing national regulations for accident prevention together with any internal working, operating and safety regulations of the operator are to be complied with.

2.5 Safety instructions for the operator

This appliance is not intended for use by persons (including children) with reduced physical, sensory or mental capabilities, or lack of experience and knowledge, unless they have been given supervision or instruction concerning use of the appliance by a person responsible for their safety or where they receive instructions from such a person as to how the device is to be operated.

Children should be supervised to ensure that they do not play with the appliance.

- If hot or cold components on the product/the unit lead to hazards, local measures must be taken to guard them against touching.
- Guards protecting against touching moving components (such as the coupling) must not be removed whilst the product is in operation.
- Leakages (e.g. from the shaft seals) of hazardous fluids (which are explosive, toxic or hot) must be led away so that no danger to persons or to the environment arises. National statutory provisions are to be complied with.
- Danger from electrical current must be eliminated. Local directives or general directives [e.g. IEC, VDE etc.] and local energy supply companies must be adhered to.

2.6 Safety instructions for installation and maintenance work

The operator must ensure that all installation and maintenance work is carried out by authorised and qualified personnel, who are sufficiently informed from their own detailed study of the installation and operating instructions.

Work to the product/unit must only be carried out when at a standstill. It is mandatory that the procedure described in the installation and operating instructions for shutting down the product/unit are complied with.

Immediately on conclusion of the work, all safety and protective devices must be put back in position and/or recommissioned.

2.7 Unauthorised modification and manufacture of spare parts

Unauthorised modification and manufacture of spare parts will impair the safety of the product/personnel and will make void the manufacturer's declarations regarding safety.

Modifications to the product are only permissible after consultation with the manufacturer. Original spare parts and accessories authorised by the manufacturer ensure safety. The use of other parts will absolve us of liability for consequential events.

2.8 Improper use

The operating safety of the supplied product is only guaranteed for conventional use in accordance with Chapter 4 of the operating instructions. The limit values must on no account fall under or exceed those specified in the catalogue/data sheet.

3 Transport and interim storage

The system is supplied on a pallet, on transport boards or in a crate and is film-wrapped to protect it against moisture and dust. Transport and storage instructions applied to the packaging must be observed.



CAUTION! Risk of material damage!

The system must be transported by means of authorised load carriers. Stability of the load must be ensured, since with this particular range of pumps, the centre of gravity has been shifted to the top (top-heavy). Transport straps or ropes must be secured to the existing transport lugs or taken round the base frame. Secure the system against being knocked over. The pipes and fittings will not withstand loads and should not be used to secure loads in transit.

CAUTION! Risk of damage!

Loading of the pipes in transit can result in leaks!

The transport dimensions, weights and necessary passageways and transport areas of the system can be taken from the supplied installation plan or other documentation.



CAUTION! Risk of damage to the product!

The system must be protected against moisture, frost and heat and also mechanical damage by means of suitable measures!

If, when unpacking the system and the accompanying accessories, packaging damage is found which could have been caused by a fall or the like, check the system and/or the accessory components for possible deficiencies.



You may wish to inform the delivery company (the carrier) or Wilo factory after-sales service, even if no product damage has yet been found.

After removing the packing, the system must be stored or installed according to the installation conditions described (see section entitled Installation).

4 Intended use

Automatic FLA fire extinguishing systems are used for supplying water to stationary, non-automatic extinguishing systems with extinguishing hose connecting equipment, e.g. for fire hose reel installations as per DIN14462.

The FLA fire extinguishing systems must be connected indirectly to the public water mains via a WILO break tank (FLA series) or a break tank to be provided by the customer (see Fig. 6a and 6b).

If it is necessary to connect the systems directly to a non-drinking water network, a special version is required.

The following standards and directives should be observed during planning and installation:

- DIN1988-600
- DIN14462
- DIN2000
- EU directive 98/83/EC
- Drinking Water Ordinance – TrinkwV2001
- DVGW regulations

Make sure that the fluid to be pumped in the system will not corrode the materials used in the system either chemically or mechanically and that it does not contain any abrasive or long-fibre constituents.

5 Product information

5.1 Type key

| For example: FLA-1HELIX V1604/K-01 PN8 | |
|--|--|
| FLA | Fire extinguishing system |
| 1 | Number of pumps (here with 1 pump) |
| HELIX-V | Names of the pump series (see also supplied pump documentation) |
| 16 | Rate volume flow of the pump Q [m ³ /h] |
| 04 | Number of pump stages |
| K | Pump with cartridge mechanical seal |
| 01 | Internal version indication |
| PN8 | Rated pressure stage of system according to max. working point (8 bar in this case) |
| For example: FLA-2MVI7006/1 PN16 | |
| FLA | Fire extinguishing system |
| 2 | Number of pumps (here with 2 pumps) |
| MVI | Names of the pump series (see also supplied pump documentation) |
| 70 | Rate volume flow of the pump Q [m ³ /h] |
| 06 | Number of pump stages |
| /1 | Number of reduced impellers |
| PN16 | Rated pressure stage of system according to max. working point (16 bar in this case) |

| 5.2 Technical data | |
|--|--|
| Max. volume flow | See catalogue/data sheet |
| Max. delivery head | See catalogue/data sheet |
| Speed | 2800 – 2900 rpm |
| Mains voltage | 3~ 400 V \pm 10 % V (L1, L2, L3, PE) |
| Rated current | See rating plate |
| Frequency | 50 Hz |
| Electrical connection | |
| Insulation class | F |
| Protection class | IP 54 |
| Power consumption P ₁ | See rating plate of pump/motor. |
| Power consumption P ₂ | See rating plate of pump/motor. |
| Nominal diameters | |
| Suction/pressure pipe connection FLA-1 | Rp 2 / R 1½ (HELIX V16.. except HELIX V1612) Rp 2 / R 2 (HELIX V1612) Rp 2 / R 2 (HELIX V22..) Rp 2½ / R 2 ½ (HELIX V36..) DN80 / DN80 (HELIX V52..) DN100 PN16 / DN100 PN16 (MVI70.. except MVI7006..) DN100 PN25 / DN100 PN16 (MVI7006..) DN100 PN16 / DN100 PN16 (MVI95.. except MVI9505..) DN100 PN25 / DN100 PN16 (MVI9505..) |
| Suction/pressure pipe connection FLA-2 | R 2½ / R 2½ (HELIX V16.. except HELIX V1612) R 3 / R 3 (HELIX V1612) R 3 / R 3 (HELIX V22..) DN100 PN16 / DN100 PN16 (HELIX V36..) DN125 PN16 / DN125 PN16 (HELIX V52..) DN125 PN16 / DN125 PN16 (MVI70..) DN125 PN16 / DN125 PN16 (MVI95..) |
| Permitted ambient temperature | 5 to 40°C |
| Approved fluids | Pure water without settling sediments |
| Admissible fluid temperature | 3 to 50°C |
| Maximum permissible operating pressure | On suction side: indirect connection only On pressure side 8 / 10 / 16 bar (see rating plate) |
| Max. permissible inlet pressure | Indirect connection (however max. 6 bar) |
| Further data... | |
| Diaphragm pressure vessel | 8 l |

5.3 Scope of delivery

- WILO-FLA fire extinguishing system
- Installation and operating instructions for WILO-FLA fire extinguishing system
- Installation and operating instructions for the pumps
- Installation and operating instructions for the control device
- Factory acceptance test certificate (in accordance with EN10204 3.1.B)
- Installation plan if applicable
- Electrical wiring diagram if applicable
- Installation and operating instructions for the signal transmitter if applicable
- Spare parts list if applicable
- Additional documentation for special versions if applicable

5.4 Accessories

Accessories must be ordered separately as required. The accessories from the Wilo range include the following:

- Dry-running protection system:
 - Float switch
 - Low-water warning electrodes with level control relay
 - Electrodes for tank operation (special accessories on request)
- Flexible connection lines
- Expansion joints
- Threaded flange
- Open break tank (FLA series)
- Diaphragm pressure vessel
- Float valve
- Flushing apparatus kit in accordance with DIN1988-600

6 Description of the product and accessories

6.1 General description

The WILO-FLA fire extinguishing system in accordance with DIN14462 is supplied as a compact unit, with all pipes installed and ready for connection (exception: if separate control device in free-standing cabinet (SG) is used). The only connections that have to be made are for the inlet, pressure and bypass pipes and the electrical mains connection.

It may also be necessary to install the supplied accessories ordered separately.

The FLA must only be connected indirectly to the water supply network (see Fig. 6a/b – system separation by a non-pressurised break tank). You will find notes on the pump type used in the attached installation and operating instructions for the pump.

Observe the relevant, applicable regulations and standards when using the fire extinguishing water supply. **The system must be operated and maintained in accordance with the relevant instructions (in Germany according to DIN 14462 und DIN 1988(DVGW)) so that the security of the fire extinguishing supply is permanently guaranteed and neither the public water supply nor other consumption installations are detrimentally affected.** The respective applicable regulations or standards (see section 1.1) on the connection and type of connection to public water supply networks are to be observed. They may be supplemented by **regulations of the water supply companies (WVU) or the responsible fire protection authority.** In addition, local conditions must be taken into account.

6.2 Components of the fire extinguishing system in accordance with DIN14462 (FLA)

The system is made up of the main components described below. The scope of delivery includes separate installation and operating instructions for the relevant operating parts/components (see also supplied installation plan).

We differentiate between series **FLA-1** (single-pump system) and **FLA-2** (redundant double-pump system).

Mechanical and hydraulic system components: FLA-1 series (Fig. 1a)

The system is mounted on a *base frame with vibration absorbers (3)*. It comprises a *high-pressure multistage centrifugal pump with a three-phase AC motor (1)*, with a *check valve (6)* on the suction side. A bypass (15) with a *needle-type throttle (11)* and a *non-return valve (7)* are fitted to the pressure side. There is also an assembly that can be shut off with a *pressure switch (12)* and *pressure gauge (9)* as well as an 8-litre *diaphragm pressure vessel (8)* with a *throughflow fitting (14)* that can be shut off. The *control device (2)* is mounted on the base frame by means of an upright support bracket (10) and ready-wired to

the electrical components of the system.

FLA-2 series (Fig. 1b)

The redundant double-pump system is mounted on a *base frame with vibration absorbers (3)*. It consists of two independently operating single-pump systems. The two *high-pressure multistage centrifugal pumps (1)* are combined by means of an *inlet collecting pipe (4)* and a *pressure collecting pipe (5)*. On each pump, there is a *check valve (6)* on the inlet and pressure sides and a bypass (15) on the pressure side with a *needle-type throttle (11)* and a *non-return valve (7)*. On the pressure collecting pipe, there is an assembly that can be shut off with three *pressure switches (12A, 12B, 12C)*, a *pressure gauge (9)*, a *bleed valve (13)*, an 8-litre *diaphragm pressure vessel (8)*, and a *check valve with a bleed valve (14)*. In the compact systems, the *control device (2)* is mounted on the base frame by means of an *upright support bracket (10)* and ready-wired to the electrical components of the system. In the case of larger systems, the control device is accommodated in a separate free-standing cabinet (SG) and the electrical components are pre-wired to the corresponding connecting cable. For the separate free-standing cabinet (SG), the final wiring is done by the customer (see section 5.3 and the documentation included with the control device). These installation and operating instructions describe the overall system in general only, without going into a detailed description of the operation of the control device (see section 7.3 and the accompanying documentation for the control device).

High-pressure multistage centrifugal pumps (1):

Different types of non self-priming, vertically installed high-pressure multistage centrifugal pumps (Helix V... or MVI...) are installed in the FLA, depending on the performance parameters required.

FLA-1 uses one pump and FLA-2 uses two pumps. The attached installation and operating instructions provide information on the pumps.

Control device (2):

Special switchgear and control devices in different designs are used to activate and control the FLA fire extinguishing systems. For information on the control device installed in this FLA, see the relevant attached installation and operating instructions.

**Pressure sensor/diaphragm pressure vessel kit
FLA-1 series (Fig. 2a)**

- Diaphragm pressure vessel with valve that can be shut off (8, 14)
- Pressure gauge (9)
- Pressure switch (12)
- Electrical connection, pressure switch (3)
- Draining/venting (13)
- Stop valve with drain (16)

FLA-2 series (Fig. 2b)

- Diaphragm pressure vessel (8)
- Pressure gauge (9)
- Pressure switches 1 to 3 (12A, 12B, 12C)
- Electrical connection, pressure switch (3)
- Venting (13)
- Stop valve with drain (14)

6.3 Function of the fire extinguishing system in accordance with DIN14462 (FLA)

The FLA fire extinguishing systems come as standard with one (FLA-1) or two (FLA-2) non self-priming high-pressure multistage centrifugal pump. The pump or pumps are supplied with water via the inlet pipe from the upstream break tank provided by the customer. The pump or pumps increase the pressure and pump the water to the consumer via the pressure pipe. To do this, they are switched on and off according to the pressure. The systems are equipped with a pressure control kit for automatic control (FLA-1 see Fig. 2a; FLA-2 see Fig. 2 b). Mechanical pressure switches (Fig. 3) are used for pressure monitoring; these switch the pump(s) on and off according to the pressure.

The mechanical pressure switch is generally used to monitor the pressure present on the consumer side of the pump. As water consumption increases, the pressure in the consumer line drops. When the minimum switch-on pressure set on the pressure switch is reached, a switching signal is sent to the control device to switch on the pump. Conversely, when consumption falls (closing of taps) the pressure in the system rises. When the switch-off pressure set on the pressure switch is reached, a switching signal is sent to the control device to switch off the pump(s). (For a more precise description of the control process, see the installation and operating instructions for the control device.)

FLA-1 (see also Fig. 2a):

When the pressure reaches or falls below the minimum switch-on pressure, the pump switches on without delay.

When the switch-off pressure is reached, the pump is switched off via a time relay in the switchgear with an optional delay of between 0 and 120 seconds (follow-up time; this is described in greater detail in the installation and operating instructions for the switchgear).

FLA-2 (see also Fig. 2b):

When the set minimum switch-on pressure for

pressure switch 1 (12A) is reached, pump 1 switches on without delay.

Pump 2 provides redundancy functions and is only started if pump 1 does not reach the set pressure (switch-off pressure for pressure switch 3 (12C)) within a time window (timer). The timer starts when the pressure falls below the switch-on pressure for pressure switch 2 and it stops when the pressure reaches the switch-off pressure for pressure switch 2. The delay created by the timer is only available again once the deactivation point for pressure switch 2 has been exceeded. Otherwise, the second pump starts as soon as the pressure falls below the switch-on pressure for pressure switch 3. (See the enclosed installation and operating instructions for the control device)

CAUTION! Safety instructions for guaranteeing function

The switch-on pressure for the second pressure switch must be larger than the switch-on pressure for the third pressure switch.

When the pressure reaches the switch-off pressure for pressure switch 1, pump 1 is switched off once the follow-up time has elapsed.

If pump 2 has started, it is switched off once the pressure reaches the switch-off pressure for pressure switch 2 and once the follow-up time has elapsed.

The fitted *diaphragm pressure vessel (8)* has a buffer effect when the system is switched on and off and it also allows small amounts of water to be extracted from the storage volume without switching on the pump. This reduces the switching frequency. The pressure gauge enables visual inspection of the current pressure. During maintenance or repair work, use the drain valve to relieve the pressure switch. See point 8.2 for information about setting the pressure switch.

CAUTION! Risk of damage!

To protect the mechanical shaft seal or slide bearing, do not allow the pumps to run dry. Leakages may be caused by a pump running dry.



6.4 Special requirements of DIN14462

6.4.1 Shut-off devices

All shut-off devices are secured in the factory against unauthorised closing or activation. After commissioning, check that these security devices still function properly.

6.4.2 Minimum extraction amount

The pumps are protected against overheating and resultant dry running in the event of reduced volume load by means of a minimum volume discharge via a bypass circuit. This circuit works without auxiliary energy. The throttle valve is pre-set in the factory and secured against unauthorised activation. The volume flow shall be discharged (e.g. back to the break tank). To do this, the pre-installed bypass line shall be expanded on site and connected above the water trap. The minimum nominal diameter and factory-configured minimum quantity are shown in the table in section 8.2.3:

6.4.3 FLA switchgear

See the enclosed installation and operating instructions for the control device.

6.5 Noise

Depending on the power requirements, the system is supplied with a wide variety of pumps which may vary considerably in terms of their noise and vibration characteristics. You will find the relevant data in the installation and operating instructions for the pump or in the catalogue specifications for the pump.

7 Setup/installation

7.1 Installation site

The installation is installed in the technical control room or in a separate, dry, well ventilated, frost-proof and overflow-proof room that can be locked (other requirements of the applicable standards to be observed).

- Adequately dimensioned drainage (drain connection or similar) must be provided in the installation room.
- No harmful gases may enter the room or be present there.
- Adequate space must be provided for maintenance work. The main dimensions are given on the attached installation plan. The system should be freely accessible from at least two sides.
- The installation surface must be horizontal and flat. The bearing surface must have adequate load-bearing capacity.
- The system is designed for a maximum ambient temperature of +0°C to 40°C at relative humidity of 50 %.
- Installation and operation in the vicinity of living rooms and bedrooms is not recommended.

- To avoid the transmission of structure-borne noise and to ensure a stress-free connection to upstream and downstream pipes, expansion joints with extension limiters or flexible connection lines should be used.



NOTE!

In the case of indirect connections, a feed-in source for the fire brigade should be provided to ensure additional fire extinguishing options.

WILO recommends providing a hydraulic connection for this type of feed-in source in each system. The current DIN 14462 standard shall be observed.

7.2 Installation

7.2.1 Foundation/bearing surface

The system is constructed for installation on flat concrete floors. The base frame is mounted on height-adjustable vibration absorbers as means of insulation against structure-borne noise.



NOTE!

For transport reasons, the vibration absorbers may not be installed upon delivery. Before installing the pressure boosting system, check that all the vibration absorbers are fitted and locked by threaded nuts. (see also Fig. 8a/b)

If the customer also wants to secure the installation to the floor, suitable measures must be taken to avoid structure-borne noise.

7.2.2 Hydraulic connection and pipes

- Connect the FLA indirectly.
- First perform all the welding and soldering work and the necessary flushing of the pipework and the supplied system before connecting the system.
- The customer's pipes must be installed without tension. Expansion joints with extension limiters or flexible connection lines are recommended for this purpose in order to avoid stress at the pipe connections and minimise the transmission of system vibrations to the building installation. In order to prevent transmission of structure-borne noise to the building, do not secure the piping to the system pipework (see Fig. 8a and 8b for example).
- The flow resistance of the suction line must be kept as low as possible (i.e. short pipe, few elbows and check valves of sufficient size).

7.2.3 Diaphragm pressure tank (accessory)

For transport reasons, the diaphragm pressure vessel (8 litre) that is part of the scope of delivery of the system may be delivered unmounted (i.e. packed separately). It must be mounted before commissioning (see Fig. 4).



NOTE

For systems of type FLA-1, ensure that the throughflow fitting is not twisted. The fitting is correctly mounted when the drain valve (see also B, Fig. 4) or rather the flow direction arrows stamped on it are parallel to the collecting pipe. If an additional larger diaphragm pressure vessel has to be installed, observe the corresponding installation and operating instructions. When installing a diaphragm pressure vessel, also make sure there is enough room for maintenance or replacement work.



NOTE!

Diaphragm pressure vessels require regular testing according to the directive 97/23/EC (in Germany, also take into account the Operating Safety Ordinance §§ 15(5) and 17 as well as Annex 5). Check valves must be provided upstream and downstream of the vessel for tests and inspection and maintenance work on the piping. To prevent system downtimes, connections for a bypass can be provided upstream and downstream of the diaphragm pressure vessel. Special maintenance and test instructions can be taken from the installation and operating instructions for the diaphragm pressure vessel concerned.

7.2.4 Safety valve (accessory)

Ensure that, in the event of a fire, no impermissible pressures will arise as a result of high temperatures. If necessary, provide safety valves to discharge the expansion water (see DIN 4753 and DIN EN1509).

7.2.5 Non-pressurised break tank (accessory)

To connect the system indirectly to the public potable water mains, it must be installed together with a non-pressurised break tank according to DIN 1988-600. The rules for the pressure boosting system apply to the installation of the break tank as well (see 7.1). The entire base of the tank must be in contact with a solid bearing surface. The maximum volume of the tank concerned must be considered when designing the load-bearing capacity of the bearing surface. When installing, sufficient space must be allowed for overhaul work (at least 600 mm above the tank and 1000 mm on the connection sides). The tank must not slant when full, because an uneven load can cause destruction. The enclosed, non-pressurised PE tank (i.e. under atmospheric pressure), which we supply as an accessory, must be installed according to the installation and operating instructions included with the tank. In general, the following procedure applies: the tank must be connected free from mechanical stresses before commissioning. This means that the connection

must be made using flexible components, like expansion joints or hoses. The tank overflow must be connected according to the regulations in force. Take suitable measures to prevent heat transmission through the connection lines. PE tanks of the WILO range are only designed to accommodate clean water. The maximum temperature of the water must not exceed 50°C. CAUTION! Risk of damage!



The tanks are designed statically for their nominal capacity. Subsequent changes can affect the static forces and cause impermissible deformations or even destruction of the tank.

The electrical wiring (for low-water protection device) to the system's control device must also be connected before the system is commissioned (see the details in the installation and operating instructions for the control device).



NOTE!

The tank must be cleaned and flushed before it is filled.



WARNING! Risk of injury or damage!

You must not walk on plastic tanks. Walking on the cover or subjecting it to loads can result in personal injury or damage to the tank.

7.2.6 Expansion joints (accessories)

For the stress-free installation of the system, the pipes must be connected with expansion joints (see example in Fig. 8a). The expansion joints must be equipped with a structure-borne noise-insulating extension limitation to absorb the reaction forces that occur. The expansion joints must be installed without tension in the pipes. No alignment errors or pipe displacement must be compensated for with expansion joints. The screws should be tightened evenly crosswise during the installation. The ends of the screws must not project beyond the flange. If welding work is done nearby, the expansion joints must be covered for protection (sparks, radiated heat). The rubber parts of expansion joints must not be painted and must be protected from oil. The expansion joints must be accessible for inspection within the system at any time and must therefore not be covered by the pipe insulation.



NOTE!

Expansion joints are subject to wear. It is necessary to regularly check for cracks or blisters, exposed fabric or other defects (see recommendations of DIN 1988).

7.2.7 Flexible connection lines (accessory)

In the case of pipes with threaded connections, flexible connection lines can be used for stress-free installation of the system and in the event of slight pipe displacement (see Fig. 8a/b for example). The flexible connection lines from the Wilo range consist of a high quality stainless steel corrugated hose, sheathed with stainless steel braiding. A flat-sealing stainless steel screw connection with internal thread is provided on one end for fitting to the system. A male pipe thread is provided at the other end to connect to further pipework. Depending on the size, certain maximum admissible deformation limits must be met

(see Table 3 and Fig. 8a and 8b). Flexible connection lines are not suitable for absorbing axial vibrations and compensating the corresponding movements. A suitable tool must be used to prevent kinking or twisting during the installation. In the event of angular displacement of the pipes, it is necessary to fixate the system to the floor, taking into account suitable measures to reduce the structure-borne noise. The flexible connection lines in the system must be accessible for inspection at any time and must therefore not be covered by the pipe insulation.

| Nominal diameter of connection | Thread of screwed connection | Tapered male thread | Permissible bend radius ∞ up to RB in mm | Max. bend angle 0 to BA in ° |
|--------------------------------|------------------------------|---------------------|---|---------------------------------|
| DN 32 | Rp 1 1/4" | R 1 1/4" | 220 | 75 |
| DN 40 | Rp 1 1/2" | R 1 1/2" | 260 | 60 |
| DN 50 | Rp 2" | R 2" | 300 | 50 |
| DN 65 | Rp 2 1/2" | R 2 1/2" | 370 | 40 |

Table 3



NOTE!

Flexible connection lines are subject to wear in operation. Regular checks for leakages or other defects are necessary (see recommendations of DIN 1988).

7.3 Electrical connection



DANGER! Risk of fatal injuries!

The electrical connection must be established in compliance with the local regulations (VDE regulations) by an electrical installation engineer approved by the local energy supply company.

To make the electrical connection, the corresponding installation and operating instructions for the control device and attached electrical wiring diagrams must be observed.

8 Commissioning/decommissioning

We recommend that the initial commissioning of the system is performed by Wilo's customer service. Contact your dealer, your nearest WILO representative or contact our central customer service department directly for details.

8.1 General preparations and control measures

Before switching on for the first time, check that all on-site wiring has been done correctly, particularly the earthing

- Check that the pipe joints are stress-free
- Fill the system and pipes and check visually for leakage
- Open the stop valves on the suction and pressure pipes
- Connect the bypass line for each pump.
- Filling and bleeding the pump: open the pump's vent screw and slowly fill the pump with water so that the air can escape completely (see also the installation and operating instructions for the pump: section regarding filling)



CAUTION! Risk of damage!

Do not allow the pump to run dry. Running dry will destroy the mechanical seal.

- Check the diaphragm pressure vessel to make sure that the supply pressure is correct (see Fig. 4 and 5). In this case, depressurise the vessel on the water side [(close the flow-through fixture or check valve (A, Fig. 4) and allow the residual water to drain (B, Fig. 4)].

Now check the gas pressure at the air valve (top; remove protective cap) on the diaphragm pressure vessel using an air pressure gauge (C, Fig. 4).

If necessary, correct the pressure if too low [(PN2 = pump switch-on pressure p_{min} less 0.2–0.5 bar) or value given in the table on the vessel (see also Fig. 5)] by adding nitrogen (contact Wilo customer service). If the pressure is too high, release nitrogen from the valve until the required value is reached. Then replace the protective cap, close the drainage valve and open the flow-through fixture/check valve.

- With system pressures greater than PN16, the manufacturer's filling instructions given in the attached installation and operating instructions must be observed for the diaphragm pressure vessel.



DANGER! Risk of fatal injury!

Excessive supply pressure (nitrogen) in the diaphragm pressure vessel can lead to damage or destruction of the vessel and thereby also to personal injury.

The safety measures for the handling of pressurised vessels and technical gases must be observed.

The pressure specifications in this documentation (Fig. 5) are made in bar(!). If other units of pressure measurement are used, always be sure to convert the figures correctly!

- Check that there is sufficient water in the break tank
- Correct installation of the right dry-running protection
- In the break tank, position the float switch or electrodes for the low-water protection device so that the signal is reported correctly at minimum water level.
- Rotation control for pumps with a standard motor: switch on briefly and verify that the direction of rotation of the pumps (HELIX-V or MVI) corresponds to the arrow on the pump housing. Swap two phases if the direction of rotation is incorrect.



DANGER! Risk of fatal injuries!

Switch off the system's main switch before swapping the phases.

- Check the motor protection to make sure that the right nominal current is set according to the specifications on the motor rating plate. Observe the installation and operating instructions for the control device when doing so.
- Check and set the operating parameters required on the control device according to the attached installation and operating instructions. Check the pressure switch setting and correct it. This setting is tuned at the factory for the optimum volumetric flow rate for operation without supply pressure.



DANGER! Risk of fatal injuries!

Contact with live parts can cause death! Use an insulated screwdriver when setting the pressure switch.

Proceed as follows when setting the pressure switch:

Pressure switch type FF4... (Fig. 3a)

- Open the pressure switch cover by unscrewing the screw plug and remove the cover.
- Open the gate valve on the discharge side and one tap.
- Set the switch-off pressure using the adjusting screw (item 19 in Fig. 3). The pressure can be read in bar on the dial (item 24 in Fig. 3). Factory setting is as shown on the attached acceptance test certificate.
- Slowly close the tap.
- Monitor the deactivation point on the pressure gauge and correct it if necessary by turning the adjusting screw (item 19 in Fig. 3).
- Slowly open the tap.
- Set the switch-on pressure using the adjusting screw (item 20 in Fig. 3). The pressure difference can be read on the dial (item 25 in Fig. 3). (The factory setting for the pressure difference Δp between deactivation and switch-on pressure is about 1.0 bar.)
- Close the tap again.
- Replace the pressure switch cover and tighten the screw plug.
- After setting the pressure switch, secure it against unauthorised adjustment (e.g. sealing).
- The **pressure switch of type FF4** is designed as a single-pole changeover contact. The switch contact is wired at the factory to open when the pressure drops and close when the target pressure is reached (the pump runs with the switch contact open).

8.1.1 Set values for the pressure switch

H(Q0) ... zero-delivery head of the system

H(geo)... geodesic head difference between highest fire hose reels and FLA

DS..A ... switch-off pressure of the relevant pressure switch(..)

DS..E ... switch-on pressure of the relevant pressure switch(..)

Setpoint... specified operating pressure of FLA

NOTE!

H(Q0) can be found in the enclosed test report for the FLA.

FLA-1:

Switch-on pressure = setpoint

Switch-off pressure = H(Q0) – 0.5 bar



| Pressure switch (1) | |
|---------------------|-----------------|
| ON DS1E | OFF DS1A |
| Setpoint | H(Q0) – 0.5 bar |

Table 4

Example: H(Q0) = 75 m (~7.5 bar)
Setpoint = 6 bar
H(geo) = 20 m (~2.0 bar)

| Pressure switch (1) | |
|---------------------|-----------------|
| DS1E 6.0 bar | DS1A 7.0 bar |

FLA-2:

H(Q0) > DS1A ≥ DS2A > DS1E ≥ DS2E ≥ DS3A > DS3E



NOTE!

The set value for pressure switch 3 ON depends on the system's hydraulic ambient variables; however, it should be within the limit values "min" and "max" in Table 5.

| Pressure switch (1) | | Pressure switch (2) | | Pressure switch (3) | |
|---------------------|-----------------|---------------------|-------------|--------------------------|-------------|
| ON DS1E | OFF DS1A | ON DS2E | OFF DS2A | ON DS3E | OFF DS3A |
| Setpoint | H(Q0) – 0.5 bar | DS1E | DS1A | min.: H(geo) + 0.5 bar | DS2E |
| | | | | max.: Setpoint – 0.5 bar | |

Table 5

For example: H(Q0) = 75 m (~7.5 bar)
Setpoint = 6 bar
H(geo) = 20 m (~2.0 bar)

| Pressure switch (1) | | Pressure switch (2) | | Pressure switch (3) | |
|---------------------|-----------------|---------------------|-----------------|-------------------------|-----------------|
| DS1E 6.0 bar | DS1A 7.0 bar | DS2E 6.0 bar | DS2A 7.0 bar | DS3E 2.5 ... 5.5 bar | DS3A 6.0 bar |

8.1.2 Setting the needle-type throttles in the bypass

The needle-type throttle is set in the factory to a specific volume flow and is secured against unauthorised activation.

If the needle-type throttle has to be reset, we recommend proceeding as follows:

The volume flow for the relevant pump's minimum flow rate can be set using the calibration method. To calibrate, you require an additional draw-off connection in the bypass line (Fig. 6a/b, item 18, feeder pipe). Select valves with minimal pressure

losses for the shut-off devices. During the calibration operation, ensure that there is no reduction by other consumers in the downstream system.

The minimum nominal diameter, calibration time and volume flow to be set depend on the pump used. See Table 6 below:

| Pump type | Volume flow to be set m ³ /h | Bypass connection (*) | | Calibration at (litre) | | | Minimum nominal diameter of bypass |
|-------------|--|-----------------------|--------|------------------------|----------------|-----|------------------------------------|
| | | R | G | 10L | 20L seconds | 30L | |
| HELIX V16.. | 1.6 | 3/4" | 1" | 23s | 45s | 68s | DN20 |
| HELIX V22.. | 2.2 | 3/4" | 1" | 16s | 33s | 49s | DN20 |
| HELIX V36.. | 3.6 | 1 1/4" | - | 10s | 20s | 30s | DN25 |
| HELIX V52.. | 5.2 | 1 1/4" | - | 7s | 14s | 21s | DN32 |
| MVI70.. | 7.0 | 1 1/2" | 1 3/4" | 5s | 10s | 15s | DN40 |
| MVI95.. | 9.5 | 1 1/2" | 1 3/4" | 4s | 8s | 11s | DN50 |

Table 6

(*) Bypass connection ... Screwed connection with male thread R (tapered pipe thread) and female thread G (cylindrical pipe thread).

The minimum nominal diameter of the bypass applies for a maximum bypass line length of 5 m. If a longer bypass line is necessary, the minimum nominal diameter of the entire bypass line should be increased by one nominal diameter for each new 5 m (or part thereof).

Proceed as follows during calibration (see also Fig. 6a/6b):

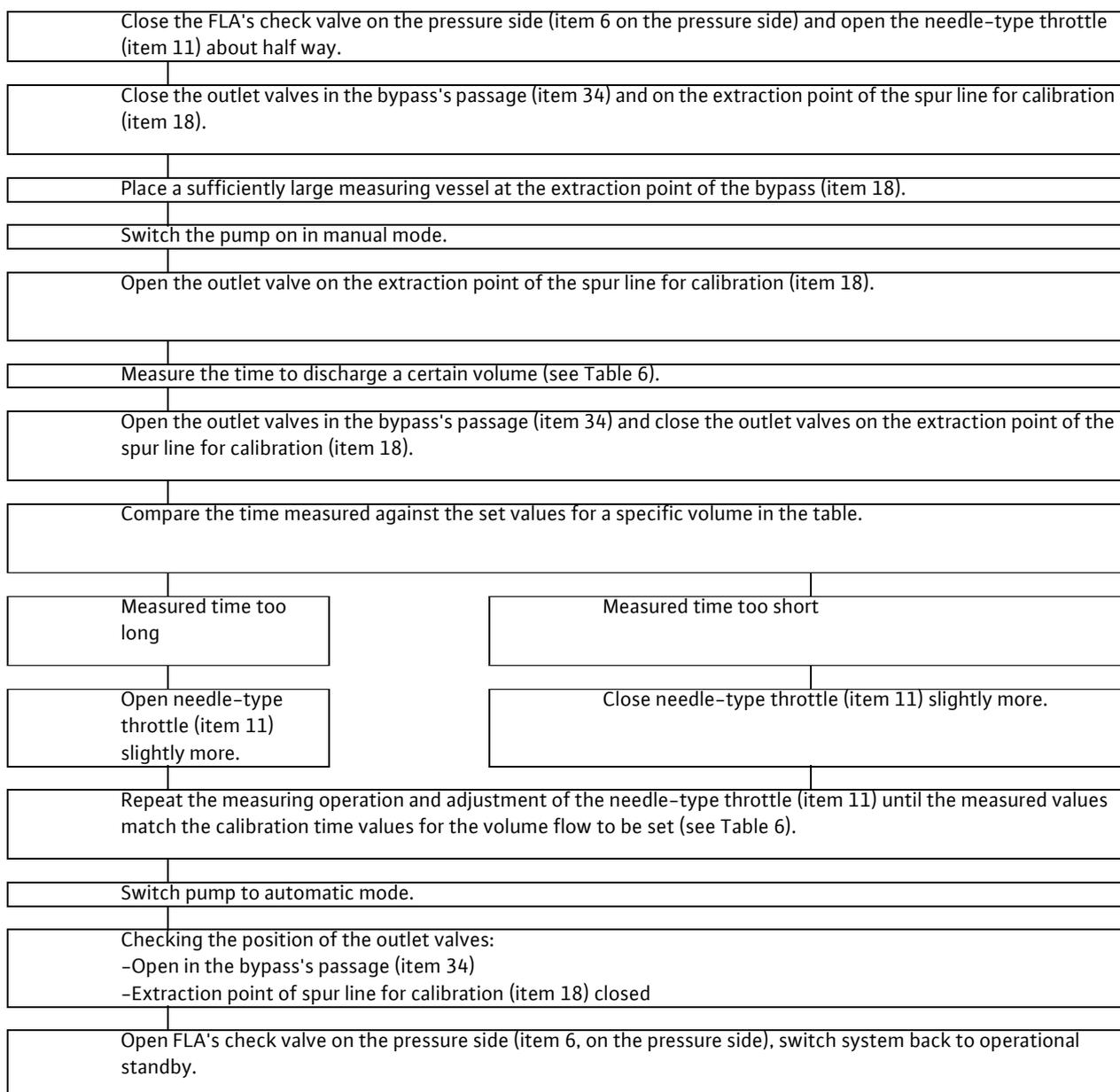

The stop valves in the bypass line must be activated in the following order after the adjustment operation:

Open passage in bypass line (item 34)/close extraction point (item 18) to ensure safe operation. The stop valves must be secured against unauthorised activation.

The needle-type throttle(s) (item 11) shall be secured against unauthorised activation after the adjustment operation (e.g. by means of sealing).

After commissioning the fire extinguishing system, check that the security devices for preventing unauthorised manipulation still function properly.

The needle-type throttle can be adjusted by the WILO customer service.

8.2 Commissioning the system

After all the preparations and checks according to section 8.1 have been made, the system should be switched on at the main switch on the control device and the control should be set to automatic mode. The pressure control system switches on the pump until the consumer piping is filled with water and the set pressure has been built up.



CAUTION! Risk of malfunction or damage!

If the system has not been flushed up to now, it should be flushed thoroughly at the latest now (see Section 7.2.2).

8.3 Decommissioning the system

If the system is decommissioned for maintenance, repair or other measures, proceed as follows:

- Switch off the voltage supply and secure it against being switched on again by unauthorised persons.
- Close the stop valves upstream and downstream of the system
- Shut off the diaphragm pressure vessel at the throughflow fitting and drain it
- Drain the system completely if necessary

9 Maintenance

To guarantee maximum operational reliability at the lowest possible operating costs, we recommend that the system is checked and maintained regularly (see DIN 14462 standard). It is advisable to conclude a maintenance contract with a specialist company or with our central customer service. The following checks should be made regularly:

- Check that the fire extinguishing system is ready to operate
- Inspection of the mechanical seal of the pump. The mechanical seals require water for lubrication, that can leak out of the seal slightly. If this is noticeable, replace the mechanical seal. Inspection of the diaphragm pressure vessel (every 3 months is recommended) to make sure the correct supply pressure is set (see Section 8.1 and Fig. 4).



CAUTION! Risk of malfunction or damage!

If the supply pressure is incorrect, the function of the diaphragm pressure vessel is not guaranteed, which increases the diaphragm wear and can cause system faults.

If the system is decommissioned for a long period, proceed as described in 8.3 and drain the pump by opening the drainage plug at the pump base. (Also observe the corresponding section in the supplied installation and operating instructions for the pump)

10 Faults, causes and remedies

Faults, particularly those affecting the pumps or the control system, should only be remedied by Wilo's customer service or a specialist company.



NOTE!

The general safety instructions must be observed during any maintenance or repair work. Also follow the installation and operating instructions of the pumps and the control device.

| Fault | Cause | Remedies | |
|--|---|---|---|
| Pump does not start | No mains voltage | Check the fuses, cables and connections. | |
| | Main switch "OFF" | Switch on the main switch. | |
| | Water level in break tank too low, i.e. low-water level reached (malfunction only occurs in test operation) | Check the break tank's inlet valve/supply line. | |
| | Low-water signal transmitter defective (malfunction only occurs in test operation) | Check and, if necessary, replace the low-water signal transmitter. | |
| | Electrodes incorrectly connected, incorrectly set (malfunction only occurs in test operation) | Check the installation or setting and correct it. | |
| | Check valve closed at pressure sensor/switch | Check and open the check valve if necessary. | |
| | Switch-on pressure set too low | Check the setting and correct it if necessary. | |
| | Switch-on/off pressures for pressure switch are not coordinated | Check the setting and correct it if necessary. | |
| | Motor protection triggered (malfunction only occurs in test operation) | Check set values against the pump or motor data, measure current values and correct setting if necessary. Check motor for defects and replace if necessary. | |
| | Contactors defective | Check it and replace it if necessary. | |
| | Turn-to-turn fault in the motor | Check, if necessary replace motor or have repaired. | |
| | Pump does not shut down. | Intake pipe blocked or shut off | Check the inlet pipe and remove the blockage or open the check valve if necessary. |
| | | Nominal diameter of the inlet pipe too small | Check the inlet pipe and increase the cross-section of the inlet pipe if necessary. |
| Inlet pipe installed incorrectly | | Check the inlet pipe and change the pipe routing if necessary. | |
| Air in the inlet | | Check and shut off the piping and vent the pumps if necessary. | |
| Impellers blocked | | Check the pump and replace it or have it repaired if necessary. | |
| Non-return valve leaking | | Check and replace the seal or non-return valve if necessary. | |
| Non-return valve blocked | | Check and remove the blockage or replace the non-return valve if necessary. | |
| Gate valve in the system closed or not sufficiently open | | Check and open the check valve completely if necessary. | |
| Flow rate too high | | Check the pump data and default values and correct them if necessary. | |
| Check valve closed at pressure sensor | | Check and open the check valve if necessary. | |
| Switch-off pressure set too high | | Check the setting and correct it if necessary. | |
| Pressure switch or cable defective | | Check pressure switch or cable and replace if necessary. | |
| Incorrect direction of rotation of the motors | | Check direction of rotation and correct by changing over phases if necessary | |

| Fault | Cause | Remedies |
|--|--|---|
| Switching frequency too high or fluttering | Intake pipe blocked or shut off | Check the inlet pipe and remove the blockage or open the check valve if necessary. |
| | Nominal diameter of the inlet pipe too small | Check the inlet pipe and increase the cross-section of the inlet pipe if necessary. |
| | Inlet pipe installed incorrectly | Check the inlet pipe and change the pipe routing if necessary. |
| | Check valve closed at pressure sensor | Check and open the check valve if necessary. |
| | Incorrect supply pressure at diaphragm pressure vessel | Check the supply pressure and correct it if necessary. |
| | Valve at diaphragm pressure vessel closed | Check the valve and open it if necessary. |
| | Switching difference set too low | Check the setting and correct it if necessary. |
| Pump not stable and/or making unusual noises | Intake pipe blocked or shut off | Check the inlet pipe and remove the blockage or open the check valve if necessary. |
| | Nominal diameter of the inlet pipe too small | Check the inlet pipe and increase the cross-section of the inlet pipe if necessary. |
| | Inlet pipe installed incorrectly | Check the inlet pipe and change the pipe routing if necessary. |
| | Air in the inlet | Check and shut off the piping and vent the pumps if necessary. |
| | Air in the pump | Vent the pump, check the suction line for leakages and seal it if necessary. |
| | Impellers blocked | Check the pump and replace it or have it repaired if necessary. |
| | Flow rate too high | Check the pump data and default values and correct them if necessary. |
| | Incorrect direction of rotation of the motors | Check direction of rotation and correct by changing over phases if necessary |
| Pump not stable and/or making unusual noises | Mains voltage: a phase is missing | Check the fuses, cables and connections. |
| | Pump not adequately secured to base frame | Check the fixation and re-tighten the fastening screws if necessary. |
| | Bearing damage | Check the pump/motor and replace it or have it repaired if necessary. |
| Motor or pump become too warm | Air in the inlet | Check and shut off the piping and vent the pumps if necessary. |
| | Bypass line closed or not sufficiently open | Check, adjust needle-type throttle if necessary. |
| | Impellers blocked | Check the pump and replace it or have it repaired if necessary. |
| | Bearing damage | Check the pump/motor and replace it or have it repaired if necessary. |
| | Turn-to-turn fault in the motor | Check, if necessary replace motor or have repaired. |
| | Mains voltage: a phase is missing | Check the fuses, cables and connections. |
| Current consumption too high | Flow rate too high | Check the pump data and default values and correct them if necessary. |
| | Turn-to-turn fault in the motor | Check, if necessary replace motor or have repaired. |
| | Mains voltage: a phase is missing | Check the fuses, cables and connections. |

| Fault | Cause | Remedies |
|---|--|---|
| Motor protection switch triggers (malfunction only occurs in test operation) | Non-return valve defective | Check and replace the non-return valve if necessary. |
| | Flow rate too high | Check the pump data and default values and correct them if necessary. |
| | Contactors defective | Check it and replace it if necessary. |
| | Turn-to-turn fault in the motor | Check, if necessary replace motor or have repaired. |
| | Mains voltage: a phase is missing | Check the fuses, cables and connections. |
| Pump generates no or insufficient power | Intake pipe blocked or shut off | Check the inlet pipe and remove the blockage or open the check valve if necessary. |
| | Nominal diameter of the inlet pipe too small | Check the inlet pipe and increase the cross-section of the inlet pipe if necessary. |
| | Inlet pipe installed incorrectly | Check the inlet pipe and change the pipe routing if necessary. |
| | Air in the inlet | Check and shut off the piping and vent the pumps if necessary. |
| | Impellers blocked | Check the pump and replace it or have it repaired if necessary. |
| | Non-return valve leaking | Check and replace the seal or non-return valve if necessary. |
| | Non-return valve blocked | Check and remove the blockage or replace the non-return valve if necessary. |
| Pump generates no or insufficient power | Gate valve in the system closed or not sufficiently open | Check and open the check valve completely if necessary. |
| | Incorrect direction of rotation of the motors | Check direction of rotation and correct by changing over phases if necessary |
| Dry-running protection switches off despite presence of water (malfunction only occurs in test operation) | Turn-to-turn fault in the motor | Check, if necessary replace motor or have repaired. |
| | Nominal diameter of the inlet pipe too small | Check the inlet pipe and increase the cross-section of the inlet pipe if necessary. |
| | Inlet pipe installed incorrectly | Check the inlet pipe and change the pipe routing if necessary. |
| | Electrodes or low-water signal transmitter connected incorrectly or adjusted incorrectly | Check the installation or setting and correct it. |
| | Low-water signal transmitter defective | Check and, if necessary, replace the low-water signal transmitter. |

You can find information on pump or control device faults not dealt with here in the supplied documentation for the components concerned.

If the operating fault cannot be remedied, please consult a specialist company or your nearest Wilo customer service or representative.

11 Spare parts

Spare parts or repairs may be ordered from local specialist retailers or Wilo customer service. To avoid queries and incorrect orders, all data of the rating plate should be submitted for each order.

Subject to change without prior notice

D EG – Konformitätserklärung
GB EC – Declaration of conformity
F Déclaration de conformité CE

(gemäß 2006/42/EG Anhang II, 1A und 2004/108/EG Anhang IV, 2,
according 2006/42/EC annex II, 1A and 2004/108/EC annex IV, 2,
conforme 2006/42/CE appendice II, 1A et 2004/108/CE l'annexe IV, 2)

Hiermit erklären wir, dass die Bauart der Baureihe :
Herewith, we declare that the product type of the series:

FLA-1
FLA-2

Par le présent, nous déclarons que le type de pompes de la série :

(Die Seriennummer ist auf dem Typenschild des Produktes angegeben./

The serial number is marked on the product site plate./ Le numéro de série est inscrit sur la plaque signalétique du produit.)

in der gelieferten Ausführung folgenden einschlägigen Bestimmungen entspricht:

in its delivered state complies with the following relevant provisions:

est conforme aux dispositions suivantes dont il relève:

EG-Maschinenrichtlinie

2006/42/EG

EC-Machinery directive

Directive CE relative aux machines

Die Schutzziele der Niederspannungsrichtlinie 2006/95/EG werden gemäß Anhang I, Nr. 1.5.1 der 2006/42/EG Maschinenrichtlinie eingehalten, mit den Abweichungen gemäß DIN 14462.

The protection objectives of the low-voltage directive 2006/95/EC are realized according annex I, No. 1.5.1 of the EC-Machinery directive 2006/42/EC, with deviations according to DIN 14462.

Les objectifs de protection de la directive basse-tension 2006/95/CE sont respectés conformément à l'annexe I, n° 1.5.1 de la directive CE relatives aux machines 2006/42/CE, avec déviation conformément à DIN 14462.

Elektromagnetische Verträglichkeit - Richtlinie

2004/108/EG

Electromagnetic compatibility - directive

Directive compatibilité électromagnétique

Angewendete harmonisierte Normen, insbesondere:

Applied harmonized standards, in particular:

Normes harmonisées, notamment:

EN 809
EN ISO 12100
EN 50178
EN 60204-1
EN 60730-2-6
EN 61000-6-2:2005
EN 61000-6-3:2007
DIN 14462

Bei einer mit uns nicht abgestimmten technischen Änderung der oben genannten Bauarten, verliert diese Erklärung ihre Gültigkeit.

If the above mentioned series are technically modified without our approval, this declaration shall no longer be applicable.

Si les pompes mentionnées ci-dessus sont modifiées sans notre approbation, cette déclaration perdra sa validité.

Bevollmächtigter für die Zusammenstellung der technischen Unterlagen ist:

Authorized representative for the completion of the technical documentation:

Personne autorisée à constituer le dossier technique est:

WILO SE, Werk Oschersleben
Quality Department
Anderslebener Str. 161
39387 Oschersleben

Dortmund, 23.09.2011

Oliver Breuing
Quality Manager



WILO SE
Nortkirchenstraße 100
44263 Dortmund
Germany

wilo



Pioneering for You